



SIEMENS

Built-in Appliances 2022 Collection

Discover appliances that are made to compliment one another and offer stand out eye-catching design. Explore exciting possibilities and innovative features with the Siemens built-in range.

The future moving in.

Siemens Home Appliances

Edition 1 August 2021

A global leader in design and technology for the home.

Siemens is the great, innovative technology brand in the home appliances sector. The name stands for outstanding engineering achievements, characterised by creativity, perfection and precision. For more than 170 years now, these values have shaped the Siemens brand and provided the basis for a continuous flow of innovations, which have constantly improved people's lives.

In the sporting world it has meant the development of technologies like 'Hawk-Eye', a system that has revolutionised the umpiring of various sports. In the home, it has led to the creation of a continuous production line of highly advanced yet brilliantly simple products.

5 years
Guarantee

As a sign of the confidence we have in the quality, reliability and performance of our products, all Built-in Siemens home appliances come with a 5 year warranty on parts and labour.

German
Engineering
Excellence

Siemens is proudly the No.1 home appliance brand in Germany. This is no accident. It is a testament to the ability of Siemens to evolve with customer needs and changing lifestyles, and to provide innovative and forward thinking appliances.

Source: Euromonitor, per Major Domestic Appliance definitions, volume brand sales, 2019



DESIGN
AWARD
2021

The iF Design Award is among the most prestigious and largest design competitions in the world. Since 1953, designers, manufacturers and users have looked to iF as a seal of excellence, a testimony of quality and a sign of excellent design. Siemens is proud to have been awarded nine iF Design Awards in 2018.

Welcome home.

Ovens	8 – 21
Coffee Machine	22 – 25
Hobs	26 – 33
Extractors	44 – 51
Cooling	52 – 61
Dishwashing	62 – 72
Installation Diagrams	73 – 77
Customer Service	78 – 79

Every connection lets your world grow.

To learn more about this technology visit siemens-home.bsh-group.com/za/

Take the next step into the future: Discover how new connections redefine your daily life with Siemens and Home Connect.

Wi-Fi enabled Siemens Home Appliances can already be operated through the Home Connect App, and now this technology connects your appliances with services of different partners (Google Home) – turning your house into a connected home.

This connectivity creates new possibilities and opportunities in your living space; such as changing the colour of your cooker hood to activating your oven from your mobile device.

Ovens and coffee centre

- **recipeWorld:** Discover a large and delicious variety of Siemens approved recipes. Select your favourite via the app and send the settings directly to the oven, straight from your mobile, tablet or smart device.
- **coffeeWorld:** Explore a wide range of additional coffee specialties from all around the world. Select your choice via the app and send the drink instruction straight to your coffee machine.
- **coffeePlaylist:** Impress your guests by asking them to submit their coffee preferences via the app. Transfer the beverage list remotely to the coffee machine and the drinks will be prepared one after the other.
- Operate the oven and coffee machine intuitively from wherever you are, for instance preheat your oven while you are on your way home or rinse your coffee machine from your bed when you wake up in the morning, ready for the day ahead.

Hobs and hoods

- **emotionLight Pro:** Change the ambience of the kitchen by projecting a different colour of light from your hood. Access up to 256 colours via the Home Connect App, perfect for parties.
- **Cooking assistant:** Use the assist tab on the Home Connect App when using the hob to help you find or select cooking methods. Send the settings directly to your hob for easier and quicker evening meals.
- With both hobs and hoods you can conveniently monitor your appliances' cooking status, turn appliances on or off or change the cooking settings via your Home Connect App, from wherever you are.
- Push notifications are a helpful guide notifying you when your appliance needs maintenance attention, such as letting you know when the filters need replacing.

Washing machines and tumble dryers

- **easyStart:** select from 5 easy options via the Home Connect App to identify the best wash or drying setting. Send this cycle type direct from your app to the machine.
- Operate laundry appliances from wherever you are and receive push notifications when the cycle is finished and, for our i-Dos model, whenever the fill status of detergent or fabric softener is getting low.



Fridge freezers

- **Camera in the fridge:** Plan ahead by checking the contents of your fridge from wherever you are. Our fridge freezer model KG56NHIF0N has two cameras in the fridge that regularly send updated internal fridge photographs to the Home Connect App allowing you to peer inside and plan ahead, even if you are at work or on your commute.
- **Manage your appliance remotely** and intuitively select and activate the ideal setting for your refrigerator. Whether you are returning from a food shop or boarding a flight, adjust your fridge temperature or setting directly using the app. Receive helpful push notifications directly to your app, such as when you leave the door open.

Dishwashers

- **easyStart:** simply select the kind of dishes and your cleaning preference on the app and Home Connect will suggest the correct cycle for your load, making chores stress free and straightforward.
- **Identify the most efficient wash** for your load and access the whole programme offering through the app with descriptions for each setting, use the app to help you identify the right wash for your cycle and send the load instructions straight to your machine.
- **Operate the dishwasher** from wherever you are to fit around your lifestyle. Check the wash time, receive push notifications to your mobile for machine maintenance or even start the machine remotely when out of home.



Say hello to the future

With the Home Connect App, you can control your Wi-Fi enabled Siemens home appliances via your smartphone. Integrate your appliances with one of the growing network of partner services that turn your house into a connected home, and let connectivity redefine the everyday.

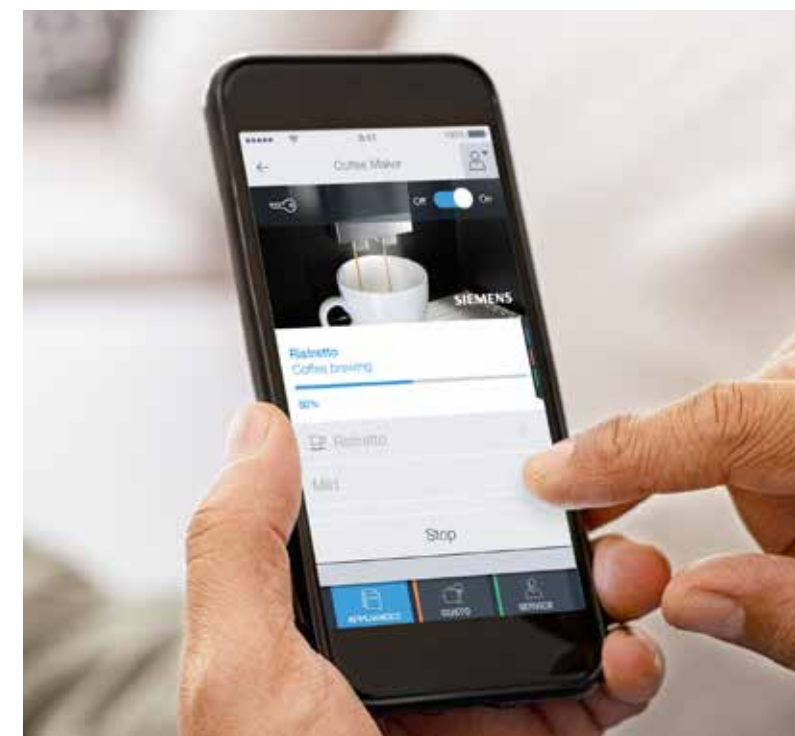
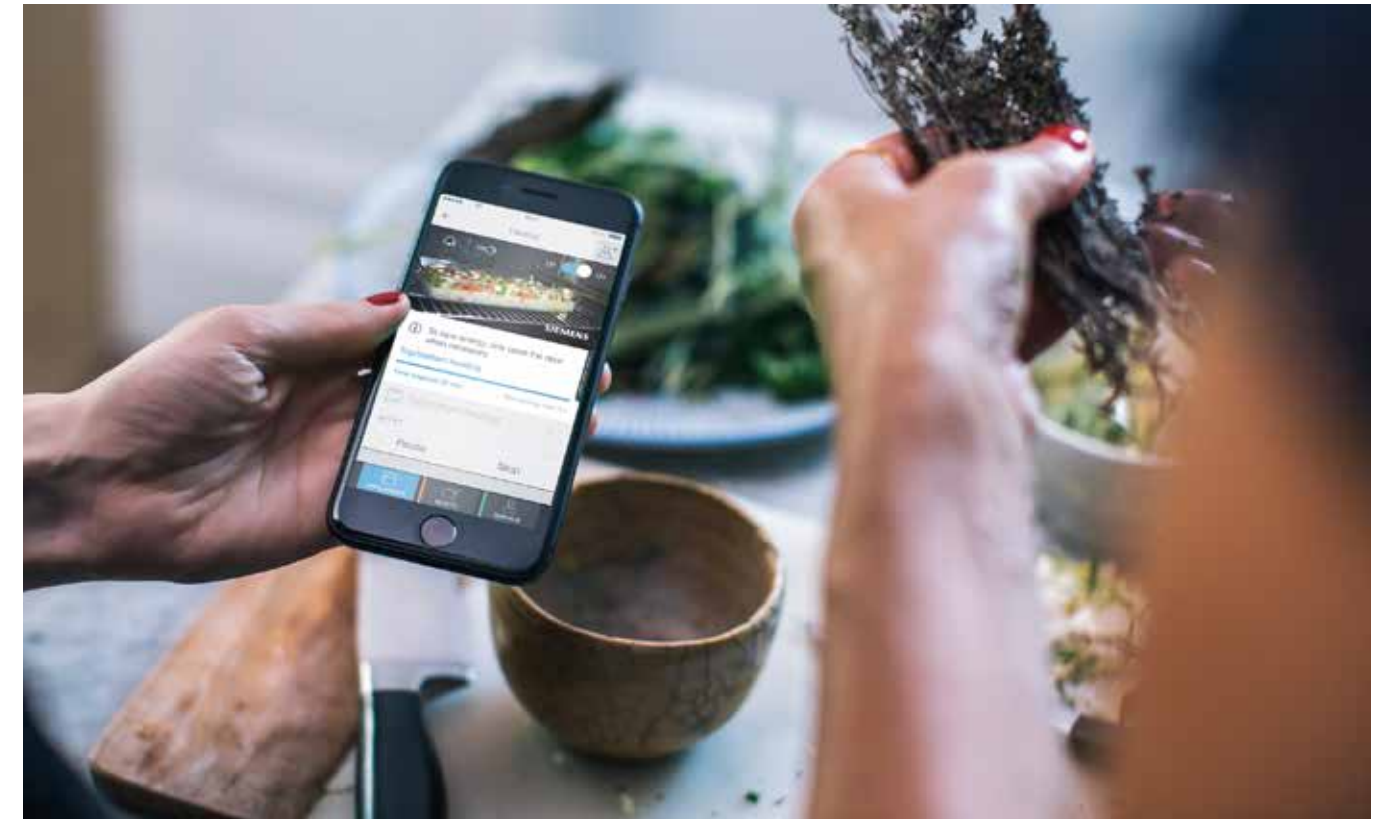

Remote Controlling and Monitoring

Ever left the house only to go back to check that you've turned off the oven? With Wi-Fi enabled Siemens cooking appliances and the Home Connect App, you can monitor and control the status of your appliance directly from your phone.

Sleek in design, intuitive in operation.



Electronic control

Depending on the function selected, the oven will suggest a suitable temperature which can be manually adjusted. The selected temperature is displayed digitally and a heating up indicator shows the progress towards the set temperature; the same indicator shows residual heat once the oven is turned off. Get quick access to performance features like cookControl and cookControl plus whilst being safe in the knowledge that if left unadjusted for a period of time, the oven will switch off automatically.

Everything put in a good light

Depending on the model, there are different kinds of illumination inside the oven. Whether it's the standard halogen light, LEDs or the most advanced Multilevel LED - Illumination, they all provide a brilliant view of your dishes without having to open the oven door.



Thanks to activeClean® and ecoClean by Siemens, cleaning your oven becomes simple and effortless.



Ovens with activeClean®

Enjoy preparing food without worrying about the consequences. Baked on food and grease can be removed at the push of a button without any need for chemical treatments. Hassle-free, the oven cleans itself thoroughly with activeClean®. It does so by heating up to a very high temperature – turning all residues into ash, which can easily be wiped away. This process is called pyrolytic and is the most convenient and efficient way to clean the whole interior of your oven. activeClean® makes it possible to forget about the chore of cleaning your oven and gives you back your time to spend on the things you love.

For iQ700, the telescopic rails and full width enameled pan are specially designed to be used with activeClean® so you don't need to remove them at all. Only the wire shelf needs to be removed.



Ovens with ecoClean

A special coating applied directly to the inside of the oven (please check specification of individual models), ecoClean makes cleaning the oven easy. The coated area cleans itself while the oven is on and models with back, roof and side coating benefit from a special cleaning programme.



Cleaning and de-scaling

Finished with a durable enameled interior, most Siemens compact45 combination ovens with steam feature dedicated cleaning and de-scaling programmes.



Drying programme

Saving the effort of wiping down the steam oven after use, the drying programme removes left over humidity inside the cavity of the oven by heating up for approximately 10 minutes.



iQ700 ovens and compacts are designed to compliment one another.

Whether you are looking for a single oven with an easy clean solution such as activeClean®, an oven with steam function or you may be considering an additional compact model with integral microwave to act as a second oven, Siemens has options for every need.

Steam and added steam cooking has increased in popularity in the past few years. Not only does this offer a more healthy cooking option, steam also retains vitamins and nutrients as well as maintaining the visual appeal of many foods.

The Siemens compact steamer and steam combination ovens provide the benefit of steam together with perfect design coordination. If coffee is your passion, then why not opt for the Siemens coffee centre – designed to coordinate with the iQ700 range, this versatile machine will provide a variety of specialist coffees at the touch of a button.

The Siemens iQ700 range also includes warming drawers. Primarily designed to pre-heat crockery and keep cooked food warm, these drawers can also slow cook, prove dough and defrost. Available in 14cm or 29cm high options, they combine perfectly with single ovens and 45cm compact models in column or side by side in block installations. For optimum design coordination, choose iQ700 models with matching TFT displays.

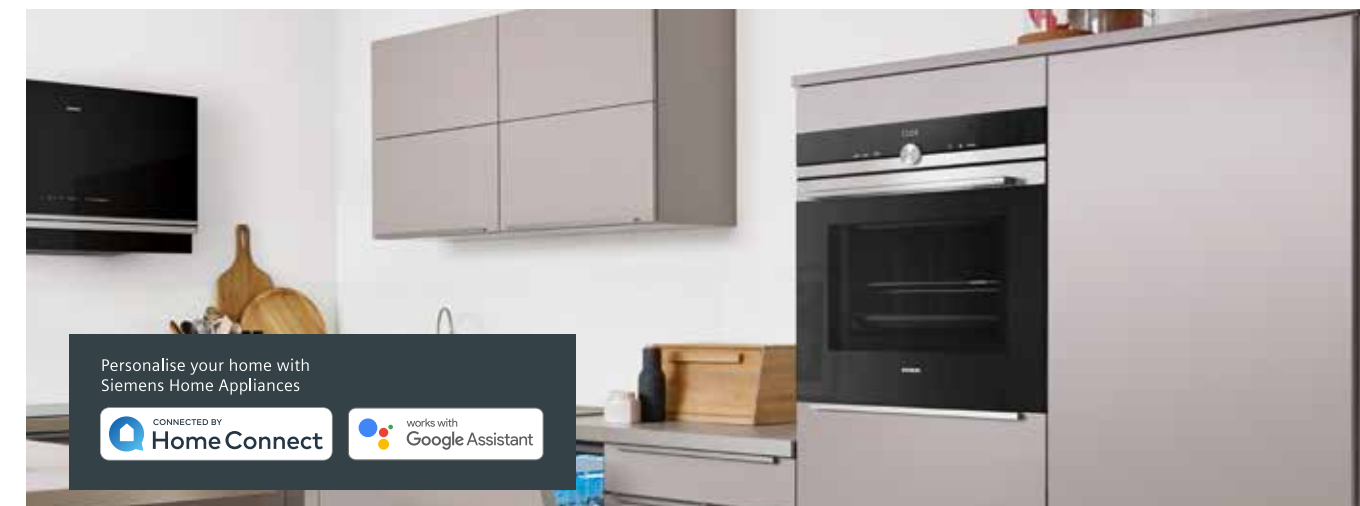

Enhanced cooking experiences with Home Connect.

Home Connect

Control your oven at the touch of an app: the Home Connect app gives you the ability to control your oven away from home remotely, for instance you can now preheat the oven on your way home. You can also control the temperature of your oven, change the cook setting, change the duration of the cooking time and even set up an oven cleaning mode from the comfort of the app.

recipeWorld

Explore an ever growing range of Siemens style recipes available on the app. Send cooking instructions for those recipes directly from the app to the appliance. The appliance will adjust the cooking time, speed and intensity based on the recipe selected.

Use voice control

Pair Amazon Alexa to your appliance and control it just by using your voice. For instance ask Alexa to change the temperature setting of the oven, or find out how much cooking time is left.

Personalise your home

With our partner app IFTTT create applets that can enhance your lifestyle. You can now use Home Connect alongside other smart home technologies that are also linked with the IFTTT app, such as lighting or music systems to create a truly connected home. For instance set up an applet to ask your lights to change colour when your dinner is ready or ask your music system to play your favourite song when your oven starts cooking - adding extra excitement and entertainment to the cooking process.

More to explore. Achieve the best results.



Easier than ever before: roastingSensor Plus
Thanks to three measuring points, the innovative roasting thermometer is able to precisely and reliably measure the core temperature of your dishes. This allows you to use it with a wider range of foods. Ideal for meat, poultry and fish, it can even be combined with the integrated microwave and the pulseSteam function. Without the need to keep checking, the roastingSensor Plus gives you the freedom to get on with the rest of your cooking. Within the range there is the roastingSensor; a temperature probe with one measuring point, so for leaner cuts of meat you can roast without worry.



bakingSensor
An oven that can detect when the baking process is complete: with bakingSensor Plus, all that is left for you to do when baking is to prepare the pastry or mix and select the required dish. Innovative sensor technology fitted inside selected iQ700 ovens can automatically control the baking process for consistently delicious baking. The bakingSensor constantly measures the moisture levels in the oven interior and is therefore able to tell you when the dish is fully cooked and ready.

The ideal kitchen helper.



cookControl Plus
Make perfect preparation easier than ever before. Select your chosen dish and enter the weight. The oven will then provide individual setting recommendations for perfect preparation of your dish ensuring the best results for a wide range of dishes, every time.



softMove
For smooth operation, when you open or close your oven door the intelligent dampers ensure that the oven door is left to open and close gently and quietly.

This automatic cooking offers up to 70 programmes to ensure meat and fish are cooked to perfection. If you're using a roastingSensor or bakingSensor, cookControl Plus will automatically suggest the mode, time and temperature for your cooking. So why make it complicated when it can be simple?



Steam cooking. The healthy way to cook



fullSteam
With the Siemens HS636GDS2 multifunction fullSteam ovens you can prepare delicious and healthy vitamin-rich dishes. Choose the fullSteam option from the 15 different functions and use only hot steam to cook the food, which is perfect for rice, fish and vegetables. You therefore retain the food's full flavour, colour, vitamins and minerals while cooking without fat or oil. The iQ700 oven is easy to use, even for someone who has never cooked with steam before.



pulseSteam
Siemens ovens and compact appliances with pulseSteam are real all-rounders for more flexibility with your cooking. It's easy to cook with steam while baking and roasting with hot air – with multifunction options you have the perfect cooking method for any food, preserving everything that is important: flavour, smell, texture, vitamins and nutrients. Siemens combi-steam ovens don't just work with hot air but also with top and bottom heating and grilling, so bread, cakes and roasts come out just right too: crisp on the outside and moist on the inside.

How does it work?

Siemens steam and steam combination ovens are quick and easy to install as they do not require plumbing-in. Our fullSteam ovens have the temperature range indicated; whereas our pulseSteam models have three intensity levels which can be adjusted, depending on what is being cooked.

The removable 1 litre water tank is accessed behind the semi-automatic control panel making it more convenient and easier to refill, even during cooking. Water is heated by a fast and efficient steam generator before being introduced into the oven. Thermostatic controls allow a pure steam temperature of 30 – 100°C.

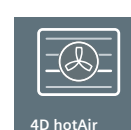

4D hotAir
Be flexible with your cooking. The innovative technology of the fan motor enables optimum heat distribution around the interior of the oven, as the oven is programmed to change the rotating direction of the fan every few minutes. Due to even distribution of heat within the cavity cooking on up to 4 shelf levels is possible. Your food therefore always turns out perfectly, just as you want it, no matter which shelf you choose to place it on.

Rail Systems: The perfect accessories, designed especially for your iQ700 oven.

We supply accessories that help make cooking easier and more enjoyable for you. Great for tailoring your oven to your individual needs offering ease of use and flexible cooking options to help you create the perfect dish.



Selected Siemens iQ700 ovens offer a single level, fully extendable Telescopic shelf rails. Designed to glide smoothly and effortlessly out of the oven, these rails offer clear and comfortable access to tend to your food during cooking and to remove the food once cooked without having to reach into the hot oven. Optional single or triple Telescopic shelf rails sets are available for all models in the iQ700 range, including versions suited to pyrolytic models which can remain in the appliance during the cleaning cycle, allowing you to effortlessly clean the oven and the rails at the same time.



Fixed level Telescopic shelf rails

Your time is precious.
Make more of it: iQ700.



Operation meets fascination:



lightControl

The new lightControl dial highlights the chosen heating symbol with a striking blue light – making operating the oven into an intuitive and exciting experience. The design is consistent throughout the iQ500 range, meaning whether you are selecting a cooking function on a single oven, or introducing steam to the 3 in 1 microwave combination compact appliance, lightControl dials will illuminate whichever function you need.



Guarantee the best cooking results:

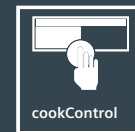

cookControl

Providing automatic programmes for mainly meat, poultry and fish. Available in either 10 programmes or 30 programmes, simply suggest the desired dish and enter the food's weight – everything else is done automatically.

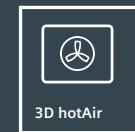

3D hotAir Plus

With the 3D hotAir, you can cook on all three levels simultaneously. Your oven distributes the heat consistently and guarantees perfect baking results while preventing flavours and smells intermingling.



Model	VB554DFR0	VB554CCR0
Product description	iQ300 90 cm built-in oven	iQ300 90 cm built-in oven
Heating methods	Bottom heat, Circulating air, Top/bottom heat, Top/bottom heat gentle, Full width grill, Hot air grilling, Hot air, Rotisserie	Bottom heat, Circulating air, Top/bottom heat, Top/bottom heat gentle, Full width grill, Hot air grilling, Hot air, Rotisserie
Comfort and safety	Oven capacity: 112 Litres Temperature range 30°C-250°C Electronic clock Oven interior light – 2 elongated halogen lights Integral cooling fan Child lock Automatic switch off	Oven capacity: 85 Litres Temperature range 30°C-250°C Electronic clock Oven interior light – 2 elongated halogen lights Integral cooling fan Child lock Automatic switch off
Design	Pop-out controls, touch controls Oven cavity with removable rack supports 1-fold telescopic rail, level independent	Pop-out controls, touch controls Oven cavity with removable rack supports 1-fold telescopic rail, level independent
Cleaning	Catalytic side liners and back panel Full glass inner door	Catalytic side liners and back panel Full glass inner door
Accessories	1 x Enamel baking tray 1 x Combination grid 1 x Universal pan	1 x Combination grid 1 x Universal pan
Product specs	Overall (H x W x D): 59.4 x 89.6 x 57.0cm Aperture (H x W x D): 60.0-60.4 x 86.0-86.4cm x 56.0cm Rating: 3300 W	Overall (H x W x D): 47.5 x 89.6 x 57.2cm Aperture (H x W x D): 47.7-48.0 x 86.0-86.4cm x 56.0cm Rating: 3100 W
Barcode	4242003802335	4242003802311



Model	HN678G4S1	HS636GDS2
Product description	iQ700 Combi microwave oven with added steam	iQ700 Full steam oven
Heating methods	4D hotAir, Hot air Eco, Top/bottom heat, Top/bottom heat Eco, Hot air grilling, Full width grill, Half width grill, Pizza setting, coolStart function, Bottom heat, Intensive heat, Slow cook, Plate warming, Drying, Keep warm Additional heating methods with steam: Regeneration, fermentation varioSpeed: heating methods combined with microwave settings 5 Microwave power settings (90 W, 180 W, 360 W, 600 W, 900 W) with Inverter	4D hotAir, Hot air Eco, Top/bottom heat, Top/bottom heat Eco, Hot air grilling, Full width grill, Half width grill, Pizza setting, CoolStart function, Bottom heat, Slow cook, Plate warming, Keep warm Additional heating methods with steam: Steam 100%, Regeneration, fermentation, Defrost
Comfort and safety	Cavity net volume: 67 Litres Temperature range 30°C - 300°C 5,7"-TFT-color and graphics display with direct touch function Temperature proposal Actual temperature display Sabbath setting Added steam function Descaling programme Automatic boiling point detection Drying function Oven door with softMove Dish categories Multipoint temperature probe Baking sensor Electronic clock Rapid heating-up LED-Elongated light, Independent oven interior light button Water tank, 1 litre Location of the steam generator is outside of the cavity Integral cooling fan Stainless-steel fan Info button Maximum window temperature 30° C Door lock electronical Child lock Residual heat indicator	Cavity net volume: 71 Litres Temperature range 30°C - 250°C 3,7"-TFT-color and graphics display with direct touch function Temperature proposal Actual temperature display Sabbath setting Added steam function Descaling programme Automatic boiling point detection Drying function Oven door with softMove Dish categories Multipoint temperature probe Electronic clock Rapid heating-up LED light, Independent oven interior light button Water tank, 1 litre Location of the steam generator is outside of the cavity Integral cooling fan Stainless-steel fan Info button Bar handle Maximum window temperature 40° C Child lock Residual heat indicator
Design	Rotary Control Cavity inner surface: Enamel anthracite Bar handle Cavity with shelf support rails, 1 level telescopic shelf, pyrolytic proof	Rotary Control Cavity inner surface: Enamel anthracite Bar handle Cavity with shelf support rails
Cleaning	activeClean® Pyrolytic proof trayholder and baking tray	Ecolyse features: back panel
Accessories	1 x Combination grid, 1 x Enamel baking tray, 1 x Universal pan	1 x Grid, 1 x Steam container, punched XL, 1 x Steam container, punched S, 1 x Steam container, unpunched, 1 x Enamel baking tray, 1 x Universal pan
Product specs	Overall (H x W x D): 59.5 x 59.5 x 54.8 cm Aperture (H x W x D): 58.5 -59.5 x 56.0 – 56.8 x 55.0 cm Rating: 3650W	Overall (H x W x D): 59.5 x 59.5 x 54.8 cm Aperture (H x W x D): 58.5 -59.5 x 56.0 – 56.8 x 55.0 cm Rating: 3650W
Barcode	4242003658789	4242003865743



Model	HM656GBS1	HB656GBS6B
Product description	iQ700 Oven with microwave	iQ 700 HomeConnect , Oven
Heating methods	4D hotAir, Hot air Eco, Top/bottom heat, Top/bottom heat Eco, Hot air grilling, Full width grill, Half width grill, Pizza setting, CoolStart function, Bottom heat, Slow cook, Plate warming, Keep warm VarioSpeed: heating methods combined with microwave settings 5 Microwave power settings (90 W, 180 W, 360 W, 600 W, 900 W) with Inverter	4D hotAir, Hot air Eco, Top/bottom heat, Top/bottom heat Eco, Hot Air grilling, Full width grill, Half width grill, Pizza setting, coolStart, Bottom heat, Slow cook, Plate warming, Keep warm
Comfort and safety	Cavity net volume: 67 Litres Temperature range 30°C - 300°C 3,7" TFT-color and graphics display with direct touch function Temperature proposal Actual temperature display Sabbath setting Oven door with softMove Dish categories electronic clock Rapid heating-up LED light, Independent oven interior light button Integral cooling fan Stainless-steel fan Info button Maximum window temperature 40°C Child lock Residual heat indicator	Cavity net volume: 71 Litres Temperature range 30°C - 300°C TFT color and text display with touch-control panels buttons Temperature proposal Actual temperature display Sabbath setting Oven door with softClose Dish categories Electronic clock Rapid heating-up LED light, Independent oven interior light button Maximum window temperature 40°C Child lock Residual heat indicator HomeConnect ready on Wi-fi
Design	Rotary Control Cavity inner surface: Enamel anthracite Bar handle Cavity with shelf support rails	Rotary Knob Cavity inner surface: Enamel anthracite Bar handle Cavity with shelf support rails (telescopic rails available as accessory)
Cleaning	Ecolyse features: ceiling, back panel, side liners Ecolyse programme/EcoClean Plus	Full glass inner door ecoClean Plus: coating of side liners, ceiling, back panel ecoClean program humidClean
Accessories	1 x Combination grid, 1 x Enamel baking tray, 1 x Universal pan	1 x Combination grid 1 x Universal pan
Product specs	Overall (H x W x D): 59.5 x 59.5 x 54.8 cm Aperture (H x W x D): 58.5 - 59.5 x 56.0 - 56.8 x 55.0 cm Rating: 3650W	Overall (H x W x D): 59.5 cm x 59.4 cm x 54.8 cm Aperture (H x W x D): 58.5-59.5 cm x 56.5-56.8 cm x 55.0 cm Rating: 3600W
Barcode	4242003658758	4242003794630



Model	HB636GBS1	HB633GBS1	HB557G450
Product description	iQ700 Oven	iQ700 Oven	iQ 500 Oven
Heating methods	4D hotAir, Hot air Eco, Top/bottom heat, Top/bottom heat eco, Hot air grilling, Full width grill, Half width grill, Pizza setting, coolStart function, Bottom heat, Slow cooking, Plate warming, Keep Warm	4D hotAir, Hot air Eco, Top/bottom heat, Top/bottom heat Eco, Hot air grilling, Full width grill, Half width grill, Pizza setting, CoolStart function, Bottom heat	3D hotAir Plus, Top/bottom heat, Hot Air grilling, Full width grill, Pizza setting, Bottom heat, hotAir gentle
Comfort and safety	Cavity net volume: 71 Litres Temperature range 30°C - 300°C 3,7" TFT-color and text display with touch-control buttons Temperature proposal Actual temperature display Sabbath setting Oven door with softMove Dish categories Electronic clock Rapid heating-up Halogen interior lighting, Independent oven interior light button Stainless-steel fan Info button Maximum window temperature 40°C Child lock Residual heat indicator	Cavity net volume: 71 Litres Temperature range 30°C - 300°C 2.8" TFT-color and text display with touch-control buttons Temperature proposal Actual temperature display Sabbath setting Oven door with softMove Electronic clock Rapid heating-up Halogen interior lighting, Independent oven interior light button Stainless-steel fan Info button Maximum window temperature 40°C Child lock Residual heat indicator	Cavity net volume: 71 Litres Temperature range 50°C - 275°C LCD Display (white) Oven door with softClose Electronic clock cookControl10 Rapid heating-up Halogen interior lighting Maximum window temperature 40°C Child lock
Design	Rotary Control Cavity inner surface: Enamel anthracite Bar handle Cavity with shelf support rails (telescopic rails available as accessory)	Rotary Control Cavity inner surface: Enamel anthracite Bar handle Cavity with shelf support rails (telescopic rails available as accessory)	Rotary Control Cavity inner surface: Enamel grey Bar handle Telescope pull-out for 3 levels, including one varioClip rail
Cleaning	Ecolyse features: back panel Full glass inner door	Full glass inner door	Full glass inner door ecoClean Plus: coating of side liners, ceiling, back panel ecoClean program
Accessories	1 x Enamel baking tray, 1 x Combination grid, 1 x Universal pan	1 x Combination grid 1 x Universal pan	1 x Enamel baking tray 1 x Combination grid 1 x Universal pan
Product specs	Overall (H x W x D): 59.5 x 59.5 x 54.8 cm Aperture (H x W x D): 58.5 - 59.5 x 56.0 - 56.8 x 55.0 cm Rating: 3650W	Overall (H x W x D): 59.5 x 59.5 x 54.8 cm Aperture (H x W x D): 56.0-56.8 x 58.5-59.5 x 55.0 cm Rating: 3650W	Overall (H x W x D): 59.5 cm x 59.4 cm x 54.8 cm Aperture (H x W x D): 58.5-59.5 cm x 56.5-56.8 cm x 55.0 cm Rating: 3600W
Barcode	4242003672402	4242003672365	4242003815335

Explore compact ovens and microwaves.

Microwave Combination Ovens*

These models are designed to provide more functionality than a solo microwave oven, focussing on combination cooking, with the microwave using higher power (max. 600W) to lead the cooking process, supported by hot air or grill functions to deliver speedy crisp and browned results. Based around a more traditional microwave functionality these models offer the perfect solution if regular microwave heating is the priority, but with the back-up of separate or combination hot air cooking and grill functionality if required.

Ovens with integral microwave*

When teamed with a single oven, Siemens compact ovens with microwave offer a great alternative to a double oven if you require more space for traditional cooking. Designed first and foremost to function as an oven, with construction, features and functions identical to a traditional single oven, these models benefit from the addition of microwaves at low medium power (max. 360W) to deliver oven-led combination cooking. Our varioSpeed faster cooking feature speeds up the cooking process while retaining traditional cooking results.

* These models are designed to operate best in combination mode, so when heating using microwave only, it may be necessary to adjust cooking times.

Inverter Technology

Inverter Technology delivers microwave power constantly while cooking – other, traditional microwaves are only able to deliver maximum power and manage the differing settings by alternating between on and off for specific time periods. This can result in uneven heating or over-cooked food and can be especially damaging to more delicate foods or smaller portions.

With Inverter technology, the microwave delivers power constantly, gradually managing the power levels down over time in order to control the food temperature. This gentle approach to cooking reduces uneven heating or overheated food and is especially beneficial for delicate foods. It may be necessary to adjust cooking times to ensure foods are thoroughly cooked before serving.

Siemens recommends that the maximum power setting be used for heating liquids and the microwave is calibrated to provide a burst of high power initially, before managing the power down in stages to the next level over the first few minutes.



Warming drawers

Perfect for warming plates, a Siemens warming drawer will keep food warm for latecomers – as well as keeping plates at an optimum temperature to ensure hot food keeps its warmth when plated. With adjustable temperatures of 40-80°C, a four-setting iQ700 14cm or 29cm high warming drawer can be installed as a standalone appliance, or acts as the perfect accompaniment to Siemens iQ700 ovens and compacts.

The perfect line up of an oven, compact appliance with warming drawer is sure to bring style and elegance to any refined kitchen space.





Model	CM656GBS1	BE555LMS0	BE634RGS1 (RIGHT HINGED) BE634LGS1 (LEFT HINGED)
Product description	iQ700 Compact oven with microwave	iQ500 Built-in microwave with grill	iQ700 Built-in microwave with grill
Heating methods	4D hotAir, Hot air Eco, Top/bottom heat, Top/bottom heat Eco, Hot air grilling, Full width grill, Half width grill, Pizza setting, coolStart function, Bottom heat, Slow cooking, Plate warming, Keep warm VarioSpeed: heating methods combined with microwave settings 5 Microwave power settings (90 W, 180 W, 360 W, 600 W, 1000 W) with Inverter	5 Microwave power settings (90 W, 180 W, 360 W, 600 W, 900 W) Grill 1.2 KW Combination of Grill and Microwave power levels 360/180/90 W	5 Microwave power settings (90 W, 180 W, 360 W, 600 W, 900 W) with Inverter Variable quartz Grill Combination of Grill and Microwave power levels 360/180/90 W
Comfort and safety	Cavity net volume: 45 Litres Temperature range 30°C - 300°C 3,7"-TFT-color and graphics display with direct touch function Temperature proposal Actual temperature display Oven door with softMove Dish categories Electronic clock Rapid heating-up LED Light, Independent oven interior light button Stainless-steel fan Info button Maximum window temperature 30° C Child lock Residual heat indicator	Cavity net volume: 25 Litres LED display cookControl 8 Memory for individual programmes (1 setting) Electronic clock LED illumination Touch key operation	Cavity net volume: 21 Litres 2,8"-TFT-color and text display with touch-control buttons cookControl 10 Side opening door LED light Info button Open door button Start-/Stop button
Design	Rotary Control Cavity inner surface: Enamel anthracite Bar handle Cavity with shelf support rails	Cavity inner surface: Stainless Steel Side opening door, left hinged 31.5 cm glass turntable	Cavity inner surface: Stainless steel
Cleaning	Ecolyse features: ceiling, side liners, back panel Ecolyse programme/ecoClean Plus	humidClean (manually)	
Accessories	1 x Combination grid, 1 x Universal pan	1 x Glass Turntable 1 x Grid	1 x Glass pan 1 x Grid
Product specs	Overall (H x W x D): 45.5 x 59.5 x 54.8 cm Aperture (H x W x D): 45.0 – 45.5 x 56.0 – 56.8 x 55.0 cm Rating: 3650W	Overall (H x W x D): 38.2 x 59.4 x 38.8cm Aperture (H x W x D): 38.0 – 38.2 x 56.0-56.8 x 55.0 cm Rating: 1450W	Overall (H x W x D): 38.2 x 59.4 x 31.8 cm Aperture (H x W x D): 36.2-36.5 x 56.0 x 30.0 cm Rating: 1990W
Barcode	4242003658369	4242003805695	BE634RGS1 (Right Hinged) 4242003676387 BE634LGS1 (Left Hinged) 4242003676363



Model	BI630DNS1	BI630CNS1
Product description	iQ700 Warmer drawer (29 cm)	iQ700 Warmer drawer (14 cm)
Cooking methods	Heating plate made of toughened glass Temperature control in 4 levels: ca. 40°C - 80°C (glass surface temperature)	Heating plate made of toughened glass Temperature control in 4 levels: ca. 40°C - 80°C (glass surface temperature)
Comfort and safety	Cavity net volume: 52 Litres Loading up to 25 kg Max. loading espresso cups: 192 PC Max. loading plates: 40PC 5 Functions: dough proving, thawing of delicate foods, keeping drinks and food warm, pre-warming of crockery, gentle cooking Telescopic pull-out drawer Cool door Push & Pull	Cavity net volume: 20 Litres Loading up to 25 kg Max. loading espresso cups: 64 PC Max. loading plates: 12PC 5 Functions: dough proving, thawing of delicate foods, keeping drinks and food warm, pre-warming of crockery, gentle cooking Telescopic pull-out drawer Cool door Push & Pull
Product specs	Overall (H x W x D): 29.0 x 59.5 x 54.8 cm Aperture (H x W x D): 29.0 x 56.0 - 56.8 x 55.0 cm Rating: 810W	Overall (H x W x D): 14.0 x 59.5 x 54.8 cm Aperture (H x W x D): 14.0 x 56.0 - 56.8 x 55.0 cm Rating: 810W
Barcode	4242003676615	4242003676561

Pure precision for perfect coffee indulgence.

Immerse yourself in the world of Siemens coffee. Kick-start your day or finish it in a relaxed mood in the evening. No matter how or when you prefer to enjoy your coffee Siemens has the right model. Such pleasure is made possible by the interaction of all components – a result of our years of experience and strong commitment to research and development.



Pure precision for perfect coffee indulgence with our built-in coffee machines.

Stunningly, uniquely Siemens, our iQ700 built-in coffee convey an elegant impression of absolute quality and intelligent innovation for those passionate about coffee.

The design of the iQ700 coffee is perfectly aligned with the entire iQ700 series. To keep the sleek lines looking clean, all milk, water and bean containers are conveniently hidden behind the coffee centre's door, while the TFT touchDisplay and LED lights put each coffee in the spotlight.

Designed with easy access to the water tank, bean holder and insulated milk jug, the coffee centre has front access thanks to a hinged front panel – so it's quick to replace the water or beans.

The milk tubes are also cleaned with steam after every coffee with milk and as most of the components are removable and dishwasher safe, they are also easy to clean. Easy to install, the machine requires no extra plumbing. Choose a built-in iQ700 coffee machine from our core collection or our top studioLine collection.



Enjoy the wide world of coffee. While relaxing on your sofa.

With Siemens EQ.9 700's bean-to-cup coffee machine and Built-in models with Home Connect, you can discover the world of great coffee in just one app and benefit from exclusive varieties and intuitive remote functions directly with a smartphone or tablet.

Home Connect

Explore new coffee varieties, by selecting drinks through the app, design coffee playlists so you and your guests can save drink preferences and send drinks to the machine so they are automatically prepared one after the other.

Personalise your home with Siemens Home Appliances



Model	CT636LE56
Product description	iQ700 Integrated fully automatic espresso/coffee machine HomeConnect
Comfort and safety	<p>Home Connect coffeeWorld: 15 additional international coffee specialties are available in the app - from Indian Kaapi to Vienna Melange to Colombian Cortado coffeePlaylist: Simply enter several drinks you would like into the app in one go. Coffee recipes: The app offers a variety of recipes involving coffee, which can be transferred to the appliance or a Home Connect capable oven - from Espresso Crème brûlée to saddle of venison with coffee crunches Coffee know-how: The app includes interesting knowledge around the topic coffee, e.g. bean varieties, harvesting methods Cleaning program: The Home connect app reminds you when an action on the device is required during a cleaning program User manual: A digital user manual is ready to hand at all times in the app</p> <p>Flavour sensoFlow System: The innovative heating system guarantees a constant brewing temperature aromaPro Concept: Ideal contact pressure for optimal aroma extraction One-touch preparation: Ristretto, Espresso, Espresso Macchiato, Coffee, Cappuccino, Latte Macchiato, Caffè Latte at the touch of a button aromaDouble Shot: Extra-strong coffee with less bitterness thanks to two grinding and brewing processes Beverage temperature adjustable individually: coffee 3 levels, hot water 4 levels</p> <p>Convenience myCoffee: Save 8 beverages with individual names and adjustable mixing ratio of milk and espresso Individual Cup volume: Cup sizes adjustable individually Coffee outlet and milk frother height-adjustable: Up to 15 cm high oneTouch DoubleCup: Prepare two cups simultaneously for all coffee and milk specialties Removable Water tank (2.4 Litres volume)</p> <p>Performance silentCeram Drive: Quiet premium grinder made from non-wearing ceramic coffeeSensor Pro: The grinding unit automatically adjusts to bean variety one-touch coffee milk specialties with especially fine-pored milk froth thanks to an innovative milk frother In addition to beverages also available separately: milk foam, warm milk, hot water Reduced heat-up time: Fastest first cup Water pump with 19 bar pressure Separate chute for ground coffee</p> <p>Cleaning Removable brewing unit: Easy and hygienic cleaning under running water autoMilk Clean: Fully-automatic steam cleaning of the milk system after every beverage Milk frother removable and dishwasher-proof singlePortion Cleaning: Complete emptying of all pipes after each brewing process Automatic rinsing program when switching off and on Drip tray and coffee grounds container removable and dishwasher-proof calc'nClean: Automatic cleaning and descaling programme</p> <p>Miscellaneous Bean container with aroma protection lid (500 g volume) Coffee outlet and keys are illuminated Grinding fineness adjustable (multi-level) Display language selectable Child safety lock: Unintended brewing process not possible</p>
Product specs	Overall (H x W x D): 45.5 x 59.4 x 38.5 cm Aperture (H x W x D): 45.0 x 56.8 x 40.0 cm Rating: 1700 W
Barcode	4242003703595



Model	CT636LES1
Product description	iQ700 Integrated fully automatic espresso/coffee machine
Comfort and safety	<p>Flavour sensoflow System: The innovative heating system guarantees a constant brewing temperature aromaPro Concept: Ideal contact pressure for optimal aroma extraction One-touch preparation: Ristretto, Espresso, Espresso Macchiato, Coffee, Cappuccino, Latte Macchiato, Caffe Latte at the touch of a button aromaDouble Shot: Extra-strong coffee with less bitterness thanks to two grinding and brewing processes Beverage temperature adjustable individually: coffee 3 levels, hot water 4 levels</p> <p>Convenience myCoffee: Save 8 beverages with individual names and adjustable mixing ratio of milk and espresso Individual cup Volume: Cup sizes adjustable individually Coffee outlet and milk frother height-adjustable: Up to 15 cm high oneTouch DoubleCup: Prepare two cups simultaneously for all coffee and milk specialities Removable Water tank (2.4 Litres volume)</p> <p>Performance silentCeram Drive: Quiet premium grinder made from non-wearing ceramic coffeeSensor Pro: The grinding unit automatically adjusts to bean variety one-touch coffee milk specialities with especially fine-pored milk froth thanks to an innovative milk frother In addition to beverages also available separately: milk foam, warm milk, hot water Reduced heat-up time: Fastest first cup Water pump with 19 bar pressure Separate chute for ground coffee</p> <p>Cleaning Removable brewing unit: Easy and hygienic cleaning under running water autoMilk Clean: Fully-automatic steam cleaning of the milk system after every beverage Milk frother removable and dishwasher-proof singlePortion Cleaning: Complete emptying of all pipes after each brewing process Automatic rinsing program when switching off and on Drip tray and coffee grounds container removable and dishwasher-proof calc'nClean: Automatic cleaning and descaling programme</p> <p>Miscellaneous Bean container with aroma protection lid (500 g volume) Coffee outlet and keys are illuminated Grinding fineness adjustable (multi-level) Display language selectable Child safety lock: Unintended brewing process not possible</p>
Product specs	Overall (H x W x D): 45.5 x 59.4 x 38.5 cm Aperture (H x W x D): 45.0 x 56.8 x 40.0 cm Rating: 1700 W
Barcode	4242003645437



Introducing the Siemens hob collection.

With intelligent technology, elegant design aesthetic and practical yet impressive functionality, Siemens hobs bring excitement and ease when creating dishes.

Induction cooking

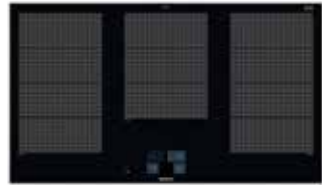

flexInduction hobs
Siemens flexInduction hobs are a must for diverse cooking. The cooking area can be tailored to your needs, enabling you to use a small area as traditional induction hobs with four or five separate zones, for boiling rice, for example, or you can choose to link the zones together to form one zone for larger cooking pans.

With flexInduction Plus, your hob automatically knows how large your cookware is. This provides even heat with the use of an additional central zone if the hob detects that the pan is too large.

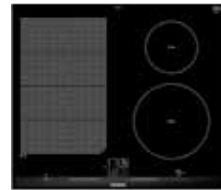

Induction hobs
Induction cooking is recognised as being one of the quickest, safest and most efficient methods of cooking available. When a pan with a ferrous or magnetic metal base is placed on the hob, the coil situated below the ceramic surface uses an electromagnetic field to create heat, almost instantly heating the pan. With only the base of the pan heated the cooking zone stays cooler.

Gas cooking



Gas hobs
Tradition meets innovation – with their modern functions, Siemens gas hobs provide enjoyment in cooking like a pro. Low profile, single piece burners on the glass complete the sleek appearance.

Domino cooking



Domino hobs
Domino hobs can be installed alone or side by side with other types of compatible hobs. Domino cooking gives you more cooking options, for example the 40cm wide Teppan Yaki is ideal for combining with other Domino or faceted design cooktops to create a bespoke cooking area.

Ceramic cooking



quickLite hobs
The surface of a glass ceramic hob heats up quickly and conveniently, while also being easy to clean due to the smooth and even surface. The cooking zones glow red when they're on and you can adjust the temperature of the cooking zones precisely, ensured by 17 power levels. Siemens highSpeed cooking zones are also optimised for fast cooking and heat up almost instantly.

Hob Accessories

For additional cooking flexibility Siemens provide a range of accessories for our flexInduction hobs.



Griddle pan
Converts your induction cooktop into a grill, specially designed for use across four flexInductors. The griddle pan maintains an even heat, perfect for frying steak or for roasting meat, fish and vegetables.



Griddle pan
HZ390522



Teppan Yaki
Heating extremely quickly the Teppan Yaki is great for fast Japanese cooking. Perfect for a cooked breakfast or a healthy stir-fry, the pan will fit across either three or four flexInductors.



40x20cm
HZ390512



Roasting dish with steamer
Perfect for use with flexInduction hobs this multipurpose dish is a must when cooking for a crowd. A removable steamer insert is available to compliment this dish and perfect for steaming vegetables.



Roasting dish
HZ390011

Steamer insert
HZ390012

Gas Accessories

Wok ring
Cooking oriental meals in a wok, requires a high temperature. This wok ring helps to regulate heat and concentrate the open flame to one area, giving you the perfect environment for your dish.

Cross support
Perfect for supporting smaller pots and pans on your hob. Whether you are using an espresso pot, or small saucepan, the cross support will give you maximum stability.

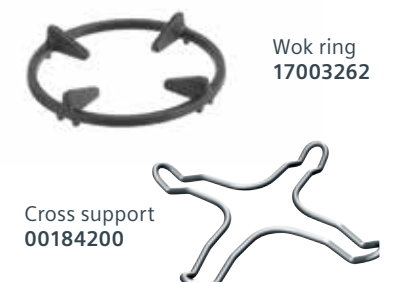

Wok ring
17003262

Cross support
00184200

Choose the perfect hob for your kitchen.

A perfect finish suitable for any modern kitchen.

We aim to provide a wide selection of quality hob choices to ensure there is enough variety and colour-ways to choose from to match your kitchen style.



Black glass



Black tempered glass



Stainless steel



Steel/black glass

Perfectly framed.

When considering a hob, you may also be thinking about the look you want to create as well as matching your appliance to other Siemens products. Siemens offers a variety of finishes to the hob frame; from stand out premium steel trims to sleek flushline trims that fit neatly in line with your worktop surface.



Flushline



Frameless



3 sided bevel edge

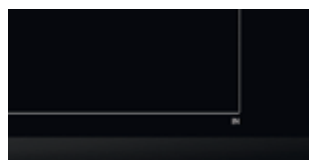

Front bevel



The perfect width.

Our hob range is available in a range of widths to suit your kitchen design and needs. Our choice of induction hobs come in 60, 80 and 90cm options, gas is available in 60, 75 and 90cm options and venting hobs come in an 80cm option.

Putting your finger on innovation.



TFT TouchDisplay



Dual LightSlider

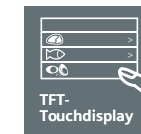

TFT Touchdisplay

With the innovative TFT Touchdisplay, you can now get the most out of your Siemens induction hob. The full colour touch screen is intuitive and easy to use with clear information about your hob's status at all times as well as additional settings that open up a new world of possibilities. Choose the settings for each individual cooking zone and combine the zones as you like – for example, for different sizes of cookware and various accessories. Access a new world of recipes available through the display screen which can help you cook the perfect dish in just a few simple steps, complete with images and clear text. Take control of your Siemens induction hob and enjoy the advanced design with perfectly prepared meals.

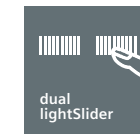

dual LightSlider

Operate with intuition. The dual lightSlider lets you easily select and join the cooking zones of the iQ700 Induction Hobs via one neatly arranged interface that illuminates when the hob is turned on. To adjust the power level of the cooking zones simply slide your finger along the lit scale or select the desired power level directly with precise control. When the hob is switched off, the controls are completely invisible for a sleek finish to your kitchen. As there are no protruding parts, cleaning is made even easier.



touchSlider



touchControl



Front Control dials



touchSlider

The ergonomic touchSlider sits flush to the appliance and allows you to slide your finger across the power level scale to the desired setting, with control advances in half-levels from 1 to 9. You can also touch the desired level directly for faster adjustments to the cooking zone temperature.



touchControl

Thanks to advanced touchControl technology, Siemens hobs can be operated by simply touching the surface. This means the controls are seamlessly integrated into the surface and make cleaning even easier.



Front Control

Gas hobs with Front Control feature all controls at the front of the appliance for ease of use.

flexInduction and induction key features.

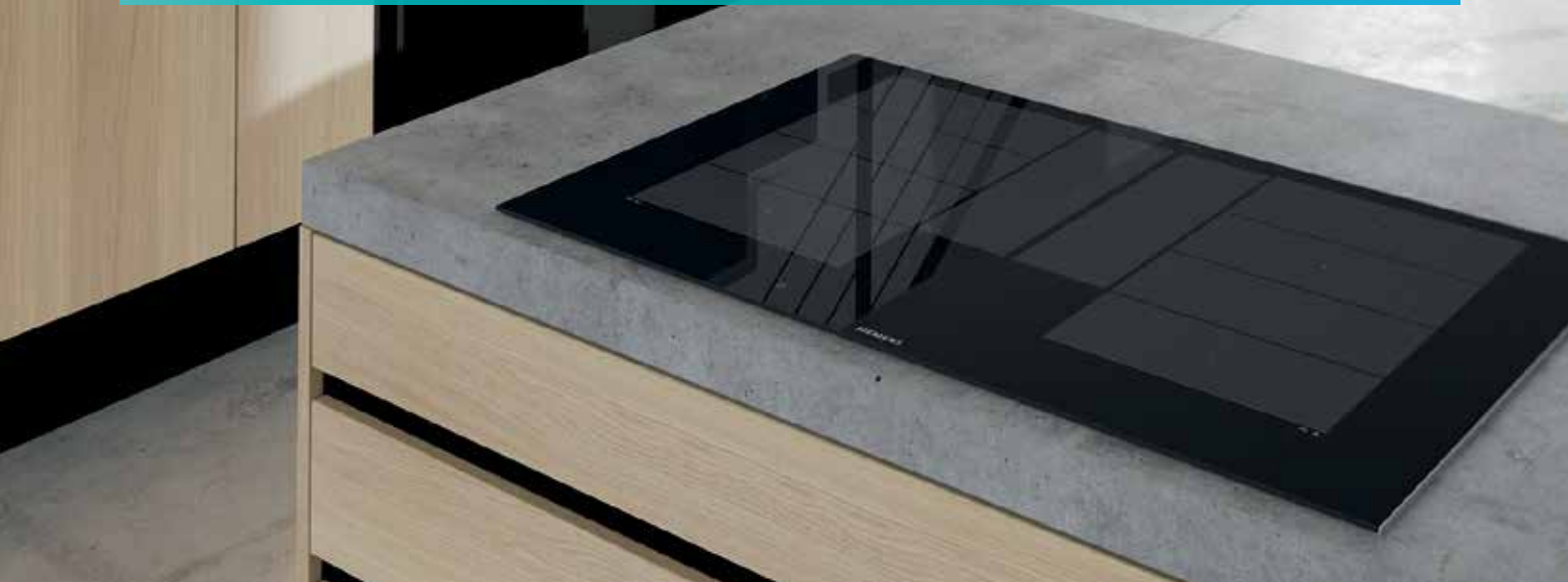

A hob that fits in with your lifestyle, flexInduction is no-compromise cooking at its best.



flexInduction

Siemens flexInduction hobs are a must for diverse cooking. The cooking area can be tailored to your needs, enabling you to use a small area as traditional induction hobs with four or five separate zones, for boiling rice, for example, or you can choose to link the zones together to form one zone for larger cooking pans. The new extended cooking surface can accommodate pans of any size, even several pans placed anywhere on the surface at the same time. With all the advantages of induction cooking, flexInduction also includes boost settings, automatic pan recognition and touchSlider controls.

Each flexInduction zone uses four innovative elongated oval inductors beneath the glass, each of which can act independently to sense the presence of cookware on the hob. Only if cookware is detected will the individual inductors work, ensuring efficient operation whether a 10cm diameter milk pan is placed in one corner or a large griddle plate covers the whole zone. With only specific areas active at any particular time, no energy is wasted. And for an even more versatile cooking experience the newly designed triple flexInduction hob provides the ultimate in flexible cooking with three flexInduction zones, fitting in with your lifestyle. flexInduction is no-compromise cooking at its best.

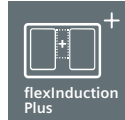

flexInduction Plus

Siemens flexInduction hobs are a must for diverse cooking. With flexInduction Plus, your hob automatically knows how large your cookware is. This provides even heat with the use of an additional central zone if the hob detects that the pan is too large. For 80cm flexInduction Plus hobs, there are two additional zones which are used for either the left or right flexInduction zones and cannot be used together. For 60cm flexInduction Plus hobs, no matter which side of the pan goes over, a central zone is automatically added.



Induction cooking – the cool heat

Induction cooking is recognised as being one of the quickest, safest and most efficient methods of cooking available.

When a pan with a ferrous or magnetic metal base is placed on the hob, the coil situated below the ceramic surface uses an electromagnetic field to create heat, almost instantly heating the pan. With only the base of the pan heated the cooking zone stays cooler.

Easier to clean and safer to use, because the ceramic cooking top is warmed only by the heat transferred back from the cookware and its contents, spillages are less likely to burn on, and there is normally no need to wait for the glass to cool down before simply wiping it over with a cloth. And if the induction hob is turned on without a pot or pan being placed on it, the hob itself will not heat up which reduces the risk of burning yourself.

Black glass finish

Our stunning induction hobs feature a black glass finish and bold displays. Our stylish collection mimicks the aesthetic of our built-in ovens and microwaves so your kitchen appliances can truly complement one another.



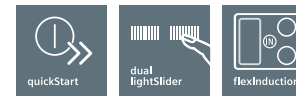
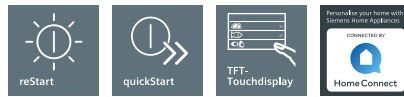

Model	EX975KXW1E	EX975LVC1E
Product description	iQ700 90cm flex induction ceramic hob, full touch TFT display	iQ700 90cm flex induction ceramic hob
Comfort and safety	5 induction cooking zones 3 flex zones flexMotion powerMove plus fryingSensor plus with 5 temperature settings cookingSensor Plus (sensor sold separately) Meal assistant Automatic pan recognition sensor powerBoost function for all zones panBoost Keep warm function for all cooking zones 17 power levels Timer with switch-off function for all zones Count-up timer powerManagement function reStart function Wipe protection function Digital 2-step residual heat indicator for each zone Wipe protection function Safety switch-off Childproof lock HomeConnect cookConnect system (with matching hood)	5 Induction cooking zones 1 Triple Zone 2 Flex induction zones Dual lightSlider touch control powerMove Plus Automatic pan recognition sensor fryingSensor Plus with 5 temperature settings powerBoost function for all zones panBoost powerManagement function reStart Function quickStart Function Energy efficiency display 17 power levels Switch off timer for every cooking zone Count-up timer symControl, symmetrical position of displays Reidual heat indicator for each zone Wipe protection function Safety switch-off Childproof lock
Design	Glass ceramic Min. Worktop thickness: 30mm	Glass ceramic Can be combined with all hobs in comfort design Min worktop thickness 30mm
Optional accessories	HZ39050 Cooking Sensor HZ390090 Wok Set HZ390011 Induction Roaster for flex induction HZ390012 Steaming rack for Roaster HZ390512 Teppanyaki for flex induction HZ390522 Griddle plate for induction HZ390220 pan diameter 19cm	HZ390011 Induction Roaster for flex induction HZ390012 Steaming rack for Roaster HZ390512 Teppanyaki for flex induction HZ390522 Griddle plate for induction HZ390250 Frying Sensor Pan Ø 21cm
Product specs	Overall (H x W x D): 5.1 x 91.2 x 52.0 cm Aperture (H x W x D): 5.1 x 88.0 x 49.0-50.0 cm Rating: 11100 W	Overall: (H x W x D): 5.1 x 91.2 x 52.0cm Aperture: (H x W x D): 5.1 x 88.0 x 49.0-50.2cm Rating: 11100W
Barcode	4242003765685	4242003705599

Model	EX675LEC1E	ET975LMP1D
Product description	iQ700 60cm induction ceramic hob faceted design	iQ300 90cm ceramic hob, electric
Comfort and safety	4 Induction cooking zones 1 flexInduction zone Dual lightSlider touch control powerMove Plus Automatic pan recognition sensor fryingSensor Plus with 5 temperature settings Boost function for all zones panBoost powerManagement Function reStart Function quickStart Function Energy efficiency display 17 power levels Switch off timer for every cooking zone timer Count-up timer symControl, symmetrical position of displays Residual heat indicator for each zone Safety switch-off Childproof lock	5 HighSpeed cooking zones: 1 triple zone, 1 dual zone, 1 combiZone Dual lightSlider touch control 17 power levels powerBoost function Digital display Switch off timer for every cooking zone Count-up timer Keep warm function for all cooking zones reStart Function Individual tunable energy consumption display Wipe protection function Digital 2-step Residual heat indicator for each zone Childproof lock Safety switch-off
Design	Faceted design (can be combined with all hobs in comfort design) Min. worktop thickness: 30 mm	Glass ceramic Min worktop thickness 20mm
Optional accessories	HZ390011 Induction Roaster for flex induction HZ390512 Teppanyaki for flex induction HZ390522 Griddle plate for induction HZ394301 Joining strip HZ390250 Frying Sensor Pan Ø 21cm	HZ394301 Joining strip HZ390011 Induction Roaster for flex induction HZ390512 Teppanyaki for flex induction HZ390522 Griddle plate for induction
Product specs	Overall (H x W x D): 5.1 x 60.2 x 52.0 cm Aperture (H x W x D): 5.1 x 56.0 x 49.0-50.0 cm Rating: 7400W	Overall: (H x W x D): 4.5 x 91.2 x 52.0cm Aperture: (H x W x D): 4.5 x 88.0 x 50.0cm Rating: 10900W
Barcode	4242003716854	4242003749562

Hob key features.

Discover the powerful responsiveness of Siemens induction cooking.

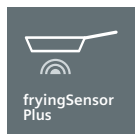

fryingSensor Plus

Makes cooking easier and ensures vegetables stay firm, and fish and meat are cooked just right. Just select the programme you want, wait for the signal, add oil to the pan – and then fry at the ideal temperature. fryingSensor Plus takes control. The integrated fryingSensor Plus gives you full precision when frying by keeping the dish at the defined power level as soon as this has been reached.



fryingSensor Plus



cookingSensor Plus

No more overboiling. Just attach the sensor to the pot and it will interact with the cooktop, giving a signal when a certain temperature has been reached and keeping it exactly at that level.



cookingSensor Plus

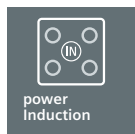

Fast, safe, and easy to clean: powerInduction from Siemens

Instantly hot. Instantly cold. Experience the benefits of Siemens powerInduction. Heat is conducted directly to the pans and their contents via induction coils, without heating the hob, heat-up times are short, safety is increased and the hob is much easier to clean.



The turbocharger for powerInduction: The powerBoost function

Increases power by up to 50%. This can save up to 35% of the time it takes to heat up pots or cook large quantities.



powerBoost



powerMove Plus

Enables intuitive control thanks to three heating zones with different temperatures, just by moving the pan.



powerMove Plus



panBoost

Enables you to heat cookware faster than when using heat setting 9. After 30 seconds, this function automatically switches itself off and reverts back to power level 9.



Combi-Zone

Allows you to connect two induction zones together, suitable for larger pots and pans.



Timer

With switch-off function. Safely shuts off the cooking zone when the selected cooking time expires.

Ceramic and gas hobs key features.



Ceramic Hobs.

Fast heating, precise control.

Hobs made of glass ceramic make your life easier. Electric ceramic hobs heat up considerably faster than conventional steel hobs and are much easier to clean. They have smooth, even surfaces and cooking zones that glow red when they're on. You can adjust the temperature of the cooking zones very precisely with multiple available power levels. Siemens highSpeed cooking zones are optimised for fast cooking and get hot instantaneously.



touchControl

Thanks to advanced touchControl technology, Siemens hobs can be operated by simply touching the surface. This means the controls are seamlessly integrated into the surface and make cleaning even easier.



controlPanel Lock

With the childproof lock button, you can quickly and easily protect the hob against unauthorised operation. The childproof lock blocks all the hob's functions at the touch of a button. Locking is cleared by pressing the button again and holding down for a few seconds.



touchSlider

The stylish and ergonomic touchSlider allows you to simply slide your finger across the touchSlider temperature scale to the desired setting. All 60cm models are controlled with one single 9.5cm touchSlider control, while the extra wide models have one, four or five touchSlider controls

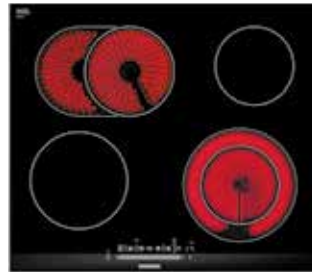

Model	ET675FNP1E	ET611HE17E
Product description	iQ300 60cm ceramic hob, electric	iQ100 60 cm ceramic hob, electric
Comfort and safety	4 HighSpeed cooking zones: 1 dual zone, 1 with extendable oval zone dual touchSlider mono 17 power levels PowerBoost function Digital display Switch off timer for every cooking zone Count-up timer reStart Function Individual tunable energy consumption display Wipe protection function Digital 2-step Residual heat indicator for each zone Childproof lock Safety switch-off	4 HighSpeed cooking zones touchControl 17 power levels Electronic display symControl, symmetrical position of displays Childproof lock Safety switch-off reStart Function Power on indicator light Main switch
Design	Glass ceramic Min worktop thickness 20mm	Frameless design HighSpeed ceramic glass
Optional accessories	HZ394301 Joining strip	
Product specs	Overall: (H x W x D): 4.5 x 60.2 x 52.0cm Aperture: (H x W x D): 4.5 x 56.0 x 49.0-50.0cm Rating: 8300W	Overall (H x W x D): 4.5 x 59.2 x 52.2cm Aperture: (H x W X D): 4.5 x 56.0 x 49.0-50.0cm Rating: 6600W
Barcode	4242003762851	4242003640388



Model	ET475FYB1E	EX375FXB1E
Product description	iQ500 40cm teppan yaki	iQ700 30cm flexinduction ceramic hob faceted design
Comfort and safety	Big stainless steel roast area touchSlider Frying area can be heated complete or halfway Electronic display Thermostat can be set between 160-240°C in steps of 10°C Special level for keeping warm (70°C) Special level for cleaning (40°C) Timer Count-up timer reStart Function Display of the heat up phase 2-fold residual heat indication Wipe protection function Safety switch-off Childproof lock	Flex zone 2 induction cooking zones Automatic pan recognition sensor powerMove Plus reStart Function quickStart Function Boost function for all zones Switch off timer for every cooking zone Count-up timer Wipe protection function Safety switch-off Childproof lock
Design	Faceted design Removable black glass lid Min. worktop thickness: 30 mm	Faceted design Min. worktop thickness: 30 mm
Optional accessories	HZ394301 Joining strip	HZ390011 Induction Roaster for flex induction HZ390512 Teppanyaki for flex induction HZ390522 Griddle Plate for flex induction HZ394301 Joining strip
Product specs	Overall (H x W x D): 9.0 x 39.2 x 52.0 cm Aperture (H x W x D): 9.0 x 36.2 x 49.0-50.0 cm Rating: 1900W	Overall (H x W x D): 5.1 x 30.2 x 52.0 cm Aperture (H x W x D): 5.1 x 27.0 x 49.0-50.0 cm Rating: 3700W
Barcode	4242003689127	4242003697405



Model	ET375FFP1E	ER3A6AD70	ER3A6BD70
Product description	iQ300 30cm ceramic hob, faceted design	iQ700 30cm gas hob with wok burner, stepFlame Technology	iQ700 30cm 2 burner gas hob, stepFlame Technology
Comfort and safety	2 HighSpeed cooking zones, including 1 dual zone touchSlider 17 power levels powerBoost function Electronic display Timer with switch-off function for all zones Count-up timer reStart function Wipe protection function Digital 2-step residual heat indicator for each zone Childproof lock Safety switch-off	1 Dual wok Burner 6.0kW stepFlame Technology Digital display to indicate power levels Electronic ignition via front control Pan supports dishwasher proof Residual heat indicator Flame failure safety device	1 Rapid burner 2.8kW 1 Standard burner 1.9kW stepFlame Technology Digital display to indicate power levels Electronic ignition via front controls Pan supports dishwasher proof Residual heat indicator Flame failure safety device
Design	To be combined with all hobs in comfort design Min. Worktop thickness: 20mm	Ceramic top sheet Cast iron continuous pan supports (dishwasher safe) Design burner - special flat design	Ceramic top sheet Cast iron continuous pan supports (dishwasher safe) Design burner - special flat design
Optional accessories	HZ394301 Joining strip	HZ394301 Joining strip	HZ394301 Joining strip
Product specs	Overall (H x W x D): 3.8 x 30.2 x 52.0 cm Aperture (H x W x D): 3.8 x 27.0 x 49.0-50.0cm Rating: 3500 W	Overall: (H x W x D): 4.5 x 30.2 x 52.0cm Aperture: (H x W x D): 4.5 x 27.0 x 49.0-50.0cm	Overall: (H x W x D): 4.5 x 30.2 x 52.0cm Aperture: (H x W x D): 4.5 x 27.0 x 49.0-50.0cm
Barcode	4242003755075	4242003742631	4242003742693



SIEMENS

Gas hobs key features.



High performance, high speed..

Tradition meets innovation – with their modern functions, Siemens gas hobs provide enjoyment in cooking like a pro. Our top-of-the-range models feature beautiful and durable black ceramic glass hob bases, with cast iron pan supports for a contemporary look. They are designed to coordinate with other appliances in the iQ700 range, and can be combined seamlessly with iQ700 domino and electric hobs. Low profile, single piece burners on the glass complete the sleek appearance.



stepFlame technology

Introducing the ground-breaking innovation in gas hobs: stepFlame. Offering 9 precise power levels to give you the control of an electric hob, with gas. No more leaning over to check the flame size, no more hoping that it is at the right heat level. All this guesswork has been removed from cooking with gas. Whatever the level selected, the exact heat and the flame size needed is provided. It is just as easy to operate as it sounds, so conjuring up delicious meals is now easier than ever. It enables you to achieve the precise results you have always dreamt of. Your meals will be delicious, and your guests will be delighted.



Cast Iron

Cast iron pan supports are designed to withstand even the heaviest of pots and pans and provide a sleek finish to each hob. All can be removed for easier cleaning and iQ700 models have dishwasher safe pan supports.

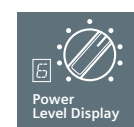

Power Level Display with residual heat indicator

Together with the new stepFlame technology, selected gas hobs feature an LED display which clearly shows the power level you have selected at a glance. For added safety, the LED display also shows whether there is any residual heat from the hob indicated by a capital 'H' for hot and a lower case 'h' for warm.



Wok burner

Siemens gas hobs feature wok burners that deliver 3.3kW, 4.0kW, 4.2kW, 5.0kW or 6.0kW of power depending on the model, meeting the increasing demand for high speed cooking. But it is not just about power; they can be turned down to just 0.3kW – perfect for simmering. For the ultimate in flexibility, our 6.0kW and 5.0kW burners are dual control – the inner and outer flame rings can be adjusted independently via a single control.



dishwasher proof

All gas on ceramic glass models feature pan supports that are treated with a special coating which resists discolouration and the damaging effects of a dishwasher.



Model	ER9A6SD70Z	ER6A6PD70
Product description	iQ700 90cm gas hob with wok burner, stepFlame Technology	iQ700 60cm gas hob, stepFlame Technology
Comfort and safety	1 Wok burner 6.0kW 1 Rapid burner 2.8kW 2 Standard burner 1.9kW 1 Economy burner 1.1kW stepFlame Technology Digital display to indicate power levels Electronic ignition via front controls Residual heat indicator Flame failure safety device	1 Rapid burner 2.8kW 2 Standard burner 1.9kW 1 Economy burner 1.1kW stepFlame Technology Digital display to indicate power levels Electronic ignition via front controls Residual heat indicator Flame failure safety device
Design	Ceramic top sheet Cast iron continuous pan supports (dishwasher safe) Design burner - special flat design	Ceramic top sheet Cast iron continuous pan supports (dishwasher safe) Design burner - special flat design
Product specs	Overall: (H x W x D): 4.5 x 91.2 x 52.0cm Aperture: (H x W x D): 4.5 x 85.0-85.2 x 49.0-50.2cm	Overall: (H x W x D): 4.5 x 60.2 x 52.0cm Aperture: (H x W x D): 4.5 x 56.0-56.2 x 49.0-50.2cm
Barcode	4242003742846	4242003742754



Model	EC9A5RB90	EC6A5HC90
Product description	iQ500 90cm gas hob with wok burner, stepFlame Technology	iQ500 60cm gas hob with Wok Burner, stepFlame Technology
Comfort and safety	1 Wok burner 5.0kW 1 Rapid burner 3.0kW 2 Standard burner 1.75kW 1 Economy burner 1.0kW stepFlame Technology Electronic ignition via front controls Flame failure safety device	1 Wok burner 3.3kW 2 Standard burner 1.75kW 1 Economy burner 1.0kW stepFlame Technology Electronic ignition via front controls Flame failure safety device
Design	Stainless Steel Cast iron continuous pan supports Design burner - special flat design	Stainless Steel Cast iron continuous pan supports Design burner - special flat design
Product specs	Overall: (H x W x D): 4.5 x 9.15 x 52.0cm Aperture: (H x W x D): 4.5 x 85.0-85.2 x 49.0-50.2cm	Overall: (H x W x D): 4.5 x 58.2 x 52.0cm Aperture: (H x W x D): 4.5 x 56.0-56.2 x 48.0-49.2cm
Barcode	4242003742204	4242003742006



Hoods with Home Connect make cooking a breeze.

Home Connect

For Wi-Fi enabled hoods with Home Connect, explore more versatile ways of cooking. Control the lighting, select a power level, or even the fan run-on option, directly using your smartphone or tablet.

Through the app you can even activate the automatic mode climateControl sensor, where the hood extractor will adjust its extraction rate depending on the amount of steam and odours so you have less to worry about when cooking.

With the cookConnect system you can even utilise the Home Connect App to connect your hood and hob together. This feature allows you to change your hood settings from the hob, so you have complete control from just one appliance.



The power to perform.

A chosen extractor must be powerful enough to effectively remove moisture and cooking odours from a kitchen. We recommend the hood should be able to change the air in the kitchen 6-12 times per hour. Using this quick calculation, you can check whether a hood is sufficiently powerful. Firstly, calculate the volume of the kitchen (HxWxD metres). Next multiply that figure by 12. The resulting figure is the ideal extraction rate required in intensive mode. Match this to a lower power level on the hood to avoid having to run at full power for increased efficiency.

FOR EXAMPLE

Room: 4m x 4m x 2.5m = 40m³

12 changes per hour in intensive operation: 12 x 40m³ = 480m³/h

So the hood must achieve >480m³/h in intensive mode.



Recirculation filters.

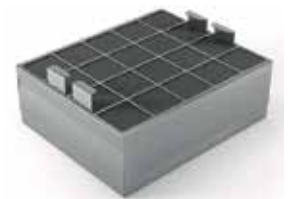

	ACTIVE CARBON FILTER	CLEAN AIR FILTER*	REGENERATIVE CLEAN AIR FILTER*
Odour reduction	Up to 86%	Up to 95%	Up to 95% or up to 86% if installed without chimney piece
Lifetime	6-12 months	12 months	10 years
Benefits	Simple installation, Anti-fish treatment	Increased surface area, High odour reduction, Up to 3dB (A) sound reduction, improved extraction and performance, Anti-fish treatment	High odour reduction, Up to 3dB (A) sound reduction, Regenerated in the oven every 4 months recommended (2 hours, 200°C), Improved extraction performance
Installation	Behind grease filters, inside the hood	Extra module required to house the CleanAir filter Option 1: stainless steel module attached to hood chimney Option 2: Integrated plastic module fitted inside the chimney piece	Extra module required (as per CleanAir filter) onto chimney or inside chimney. Chimless installation possible (Angled and flat hoods only)

*CleanAir and Regenerative filters not available for all styles of hood. Additional module may be required to house the filter. Images for example only, different filters may come in a different size and style.

State-of-the-art efficiency with our iQ700 hoods with iQ drive.

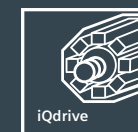

Siemens iQ700 hoods feature innovative technology that saves energy. This is thanks to the highly efficient, durable brushless iQdrive motor which is powerful, but requires very little energy to run. Capable of handling odours and grease in the most challenging cooking situations, and specially designed to last longer. The brushless iQdrive motor at the heart of our selected iQ700 hoods is capable of extracting a measured value of up to 991m³/h in our most powerful hood*.

*LC91KWW60B



Installation solutions for every kitchen.

Worktop installation.

downDraft hood.



The perfect solution for keeping your kitchen design clear and with unobstructed sightlines, this worktop ventilation system doesn't need any wall or ceiling mounts. When the ventilation system is integrated into your hob, it is able to extract cooking smells right at the source.

Ceiling installation.

Island and ceiling hoods.



Ideal if your hob is in the centre of your room. Our ceiling hoods can either be bold design statements installed over island units, or blend as unobtrusively into the ceiling itself as standard kitchen lighting.

Wall installation.

Chimney hoods.



Our stylish wall-mounted ventilation can be as beautiful and design led as they are effective. Our stunning angled and flat hoods provide a classic but contemporary ventilation solution.

Integrated furniture installation.

Canopy, telescopic and integrated hoods.



If you need to blend the hood into existing wall-mounted kitchen units, choose from a number of options perfect for mounting inside a cupboard space. These concealed hoods are ideal for a sleek modern kitchen.



Model	LD98WMM60B	LD97DBM60B (WHILE STOCKS LAST)
Product description	iQ700 90cm downdraft extractor, clear glass exhaust or recirculation operation	iQ700 90cm downdraft extractor exhaust or recirculation operation
Comfort and safety	Downdraft for a regular or seamless installation in worktops Extension height: 250 mm Electronic control via touchControl 3 Speed settings plus 2 intensive settings Automatic reset facility from intensive to normal setting Automatic 10min. run on facility Air quality sensor Cooktop-based hood control (with matching cooktop) interval function: available via Home Connect silence function: available via Home Connect Activate Guided Air to guarantee nearly perfect extraction, regardless of pot height and pot position on the cooktop The filter service button automatically lifts filters into service position for easy removal Saturation indicator for metal and charcoal filter Metal grease filter, dishwasher safe NB: No combination with gas cooktops allowed	Downdraft for a regular or flush installation in worktops. Extension height: 300 mm Electronic control via touchControl 3 Speed settings plus 2 intensive settings Intensive setting with 5 or 10 minute reset facility Automatic 10min. run on facility Capacitor motor Rim Ventilation Saturation indicator for metal and charcoal filter Metal grease filter, dishwasher safe NB: In recirculation mode no combination with gas cooktops allowed *The motor can be fitted at a max. distance of 3m from the appliance (special accessory required) *The motor can be turned on all four sides and fitted on the front or the rear
Design	Clear Glass panel extendable via lift motor Not illuminated For seamless worktop installation a special accessory is required	7W LED Module
Special accessories	LZ29WWY12 Mounting kit for seamless installation LZ21WWM11 Installation kit remote motor LZ21WWJ12 Long Life recirculation kit	LZ29IDP00 Long life recirculating Kit LZ29IDQ00 Long life odor Filter (replacement) LZ29IDM00 Mounting Kit Remote Motor
Product specs	For technical dimensions please refer to page: 29 Rating: 300 W Max. Extraction: 519m³/h Boost Extraction: 733m³/h Noise level: 62dB	For technical dimensions please refer to page: 29 Rating: 317W Max. Extraction: 530m³/h Intensive Extraction: 750m³/h Noise level: 62dB
Barcode	4242003907122	4242003823385



Model	LR97CAQ50	LF97BBM50
Product description	iQ500 90cm ceiling extractor exhaust or recirculation operation	iQ300 90cm island extractor exhaust or recirculation operation
Comfort and safety	Ceiling mounted extractor Electronic control / remote control 3 Speed settings plus 2 intensive settings Automatic reset facility from intensive to normal setting Automatic 10 min. run on facility Efficient BLDC-technology Twin channel high performance fan motor Rim Ventilation cookConnect system Saturation indicator for metal and charcoal filter Metal grease filter, dishwasher safe *Home Connect for connected home appliances and operation via smartphone or tablet	Electronic control via touchControl 3 Speed setting plus intensive setting Automatic revert setting, 6 min Capacitor Motor Metal grease filter, dishwasher safe
Design	4 x 3W LED	4 x 1.5W LED
Min. clearance above cooking point		Gas Appliance: 65.0cm (min) Electrical Appliance: 55.0cm (min)
Special accessories	LZ20JCD50 Long life recirc kit inox LZ00XXP00 Long life odor filter (replacement)	LZ53850 recirculating Kit LZ53451 Odor Filter (replacement) *LZ57600 cleanAir recirculating Kit *LZ31XXB16 CleanAir Active Carbon Filter NEW ***LZ22CB114 recirculating kit ***LZ32CBB14 Odor Filter (replacement)
Product specs	For technical dimensions please refer to page: 30 Rating: 174W Max. Extraction: 458m³/h Intensive Extraction: 798m³/h Noise level: 56dB	For technical dimensions please refer to page: 28 Rating: 256W Max. Extraction: 438m³/h Intensive Extraction: 754m³/h Noise level: 57dB
Barcode	4242003834015	4242003832080

Model	LC95KA670	LC95FCJ60T
Product description	iQ100 90 cm inclined design wall mounted extractor exhaust or recirculation operation	iQ300 90cm flat design wall mounted extractor exhaust or recirculation operation
Comfort and safety	Electronic control via touchControl 3 Speed settings Twin channel high performance motor Rim Ventilation Metal grease filter, dishwasher safe	Electronic control via touchControl 3 Speed levels Rim ventilation Metal grease filter, dishwasher safe
Design	Black with glass canopy Lightning: 2 x 3W LED	Black with glass Lightning: 2 x 1W LED spot
Min. clearance above cooking point	Gas Appliances: 57.0 cm Electrical Appliances: 47.0cm	Gas Appliance: 55.0cm (min) Electrical Appliance: 45.0cm (min)
Special accessories	LA10LKA6 Active Carbon Filter	LA10KP6A Odor Filter
Product specs	For technical dimension please refer to page: 29 Rating: 216 W Normal Extraction: 580m³/h Noise level, max normal use: 70dB	For technical dimension please refer to page: 30 Rating: 252W Max. Extraction: 649m³/h Noise level normal use: 68dB
Barcode	4242003809556	4242003899564



Model	LC67KHM60	LC94BBC50
Product description	iQ300 60 cm inclined design, wall mounted extractor exhaust or recirculation operation	iQ100 90cm wall mounted extractor exhaust or recirculation operation
Comfort and safety	Electronic control via touchControl 3 Speed settings plus intensive setting Energy efficient capacitor motor Twin channel high performance motor Rim Ventilation 2 Capture areas: front side and bottom side Saturation indicator for metal filter and charcoal filter Filter cover glass Metal grease filter, dishwasher safe	Push buttons for extractor speeds and light 3 Speed settings Twin channel high performance motor Metal grease filter, dishwasher safe
Design	Black with glass canopy In recirculation operation chimless use is possible Easy wall mounting system Lighting: 2 x 1.5W LED	Lightning: 2 x 1.5W LED
Min. clearance above cooking point	Gas Appliances from upper edge of pan support: 60.0cm Electric Appliances: 45.0cm	Gas Appliances: 65.0 cm Electrical Appliances: 55.0cm
Special accessories	LZ10AKU00 Recirculation Kit LZ10AKT00 Recirculation Kit for chimless use LZ10AKA00 Active Carbon Filter LZ11AKI16 CleanAir Recirculation Kit* LZ31XXB16 CleanAir Active Carbon Filter* *Available on request	LZ10DXU00 Recirculation Kit LZ10DXA00 Active Carbon Filter LZ11FXC56 CleanAir Recirculation Kit* LZ31XXB16 CleanAir Active Carbon Filter* *Available on request
Product specs	For technical dimension please refer to page: 29 Rating: 263W Normal Extraction: 400m³/h Intensive Extraction 660m³/h Noise level, max normal use: 57dB	For technical dimension please refer to page: 29 Rating: 100 W Normal Extraction: 330m³/h Noise level, max normal use: 64dB
Barcode	4242003760918	4242003811177



Model	LC66BHM50	LB53NAA50	LB75565
Product description	iQ300 60 cm wall mounted extractor exhaust or recirculation operation	iQ 100 60cm canopy extractor Exhaust or recirculation operation	iQ300 75cm canopy cooker hood exhaust or recirculation operation
Comfort and safety	Electronic control via touchControl 3 Speed settings plus intensive setting Twin channel high performance motor Automatic revert setting, 6min Metal grease filter, dishwasher safe	Push buttons for extractor speeds and light 3 speeds Single motor Metal grease filter, dishwasher safe	Sliding switch control 3 speed settings plus intensive setting Twin motor Metal grease filter, dishwasher safe
Design	Lighting: 2 x 1.5W LED	Fully integrated Lighting: 2 x 4 W LED	2 x LED spot 2,15W
Min. clearance above cooking point	Gas Appliances: 65.0cm Electrical Appliances: 55.0cm	Gas Appliances: 65.0cm Electrical Appliances: 55.0cm	Gas Appliances: 65.0cm (From edge of pan support) Electrical Appliances: 65.0cm
Special accessories	LZ10DXU00 Recirculation Kit LZ10DXA00 Active Carbon Filter LZ11FXC56 CleanAir Recirculation Kit* LZ31XXB16 CleanAir Active Carbon Filter* *Available on request	LZ10INT00 Recirculating Kit LZ10INA00 Active Carbon Filter	LZ73050 Active Carbon Filter
Product specs	For technical dimension please refer to page: 28 Rating: 220W Normal Extraction: 368m³/h Intensive Extraction: 605m³/h Noise Level, max. normal use: 48dB	For technical dimensions please refer to page: 29 Rating: 121W Max Extraction: 300m³/h Noise level: 61 dB/300m³/h	For technical dimensions please refer to page: 29 Rating: 206W Normal Extraction: 379m³/h Intensive Extraction: 638m³/h Noise level, normal use: 56dB
Barcode	4242003804919	4242003838914	424203838402

Intelligent refrigeration and freezing appliances for long lasting freshness.

Siemens built-in cooling appliances provide the ultimate way to store food flexibly and correctly for even more freshness.

Now you are finally able to combine Siemens cooling appliances exactly the way you want – with the right combinations for every individual requirement, taste and kitchen design. Siemens built-in fridges, freezers and wine coolers come in a wide range of models so that you have full flexibility when planning your kitchen.

Siemens cooling warranties:

5
Year Warranty

5 Year Warranty

A Siemens Five Year Warranty is available on all Siemens built-in cooling models listed in this brochure to protect against any manufacturing and material faults and defects during this warranty period.

Compressor Drive
10
Year Warranty

Compressor Drive 10 Year Warranty

Available on selected Siemens built-in fridges and fridge freezers, this warranty covers defects in the compressor motor.



Explore more cooling features.

Energy efficient cooling



Nearly every cooling appliance in the new Siemens built-in range is up to 20% more energy efficient than its equivalent A-rated appliance.

With ratings from A+++ to A, discover our range of energy efficient cooling appliances.

Type of control



In-door LCD display precision control at the touch of a button. The in-door LCD display allows the optimum temperature for food to be maintained easily, which in turn keeps your food fresher for longer.



Interior LCD display

LED Light



The new integrated long-lasting LED lights available on most of our range fit flush in the side walls or ceiling and illuminate the interior uniformly and perfectly without blinding you.



Storage solutions for all of your needs



Telescopic rails



Ergonomically ideal access
Fully-retractable drawers on telescopic rails create an easy access shelving zone. This allows you to easily pull the drawers out further, giving you a better overview of all food items and making them easier to remove.



Bottle rack



Bottle rack
Available on some models, the perfect place to store wine of all varieties and make the best use of space in your fridge. The wave shaped bottle rack can be positioned in a variety of places and safely stores bottles without them rolling back and forth.



freshProtectbox



freshProtectbox
Provides the optimum temperature for individual foods, allowing them to stay fresher for longer. Fresh ingredients are critical to delicious meals, but also count for less wastage and fewer trips to the supermarket – saving you, the consumer, time and money.

Keep your food fresher for longer: hyperFresh technology.



Set the right conditions to ensure your food stays fresher for longer: hyperFresh humidity drawers and 0°C chiller drawers.



Freshness controlled: hyperFresh
Simply use the stylish control panel to adjust the humidity in the fridge. The hyperFresh drawer with rippled base allows cool air to circulate around your fruit and vegetables easily. As a result, the quality and freshness of your food will be retained.



Shelf life maximised: hyperFresh Plus
The hyperFresh Plus drawer doesn't just store food, it provides the right conditions to keep them fresher for longer. Whether it's fruit or vegetables, increase shelf life and reduce food wastage. Simply switch between the 2 control settings, and the humidity will be adjusted for optimum storage of your food.

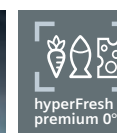

Food stays fresh for longer: hyperFresh premium 0°C
Enjoy fresher food with hyperFresh Premium 0°C. With a choice of 3 humidity controls, simply select whether it's fruit, vegetables, or both that you want to store. The hyperFresh Premium 0°C drawer will regulate how much humidity your food receives. Be in control; these innovative drawers help to keep in nutrients and minerals to create delicious meals and fewer trips to the supermarkets, saving you time, effort and money. hyperFresh Premium 0°C is available in selected Siemens single door fridges only.



hyperFresh premium 0°C chiller drawers.
Perfectly fresh for fish and meat:
hyperFresh and hyperFresh Plus models: The two hyperFresh 0°C chiller drawers are especially designed for the storage needs of fish and meat. Keep them fresher in ideal conditions near 0°C to retain the vitamins and minerals for longer. With two separate compartments the transfer of unpleasant smells will be avoided.
hyperFresh Premium models: These variants come complete with a larger full-length 0°C chiller drawer, where fish and meat are stored at the perfect temperature.

With noFrost technology you'll never have to defrost the freezer again.



noFrost
Defrosting the freezer is now done automatically. Siemens freezers are equipped with intelligent sensor-controlled technology to save the chore of defrosting the freezer. An air-circulation system guides the humidity to the outside of the refrigerator into an external evaporation tray, and sensors measure the degree of humidity and any frost production – ensuring the appliance is periodically defrosted without the need to turn off the appliance or empty it out. Also, ice no longer forms on the inside of the refrigerator, and the appliance's energy consumption remains consistently low.



lowFrost
For those models that come with lowFrost, life is still made easier. lowFrost reduces the build-up of frost by up to 50%, so there is no need to defrost the freezer as often, only once every 3 to 4 years. Designed to save you time and provide added convenience, you can spend your time on the things you enjoy, not defrosting your freezer.



Storage made easy with bigBox



Big enough for your lifestyle, the bigBox has the capacity for storing whole frozen turkeys, as well as the height to hold dessert glasses upright. Ideal for the holidays and entertaining.



Model shown: KA92NLB35G American fridge freezer



superFreeze function
superFreeze makes sure that warmer food added to the freezer doesn't raise the freezer temperature, stopping food partially defrosting.



Easy to refill for continuous ice: the iceTwister
Enjoy your own personal ice cube service. Simply activate the iceTwister and receive up to 20 ice cubes at once right away. The water tank is very easy to remove for reliable refilling.



superCool
You can use the superCool button to quickly reduce the temperature in the refrigerator to +2 °C. This prevents an undesirable rise in the temperature of your already chilled food whenever you add food that is not as cold.



iceDispenser
Models with this feature are able to dispense ice when needed thanks to a plumbed water connection. Depending on model, ice is available as cubes or crushed.

Model	KI86SAFE0
Product description	iQ500 265 litre integrated low frost fridge freezer combination
Product features	4 Freezer 100% CFC/HFC free Touchcontrol – 7 segment control LED interior light in fridge section freshSense - constant temperature by intelligent sensor technology Low frost freezer Two Cooling Systems superCool function superFreezing function Acoustic open door warning system Optical and Acoustic Warning System by Temperatur increase, with memory function Holiday mode Freezing capacity: 7kg in 24 hours Door right hinged, reversible
Interior features of fridge section	Extremely bright interior light 5 safety glass shelves(4 height adjustable) of which 1 x varioShelf divisible and 1 extendable easyAccess shelf 5 door bins, there of 1 x dairy compartment hyperFresh Plus Box with humidity control – keeps fruit and vegetables up to 2 x fresher
Interior features of freezer section	varioZone - removable safety glass shelves for extra space! 3 transparent freezer drawers including 1 bigBox
Product specs	Rating: 90W Capacity top fridge: 192 litres net Capacity bottom freezer: 74 litres net Energy consumption: 219 kWh/pa Overall (H x W x D): 177.2 x 55.8 x 54.5 cm Aperture (H x W x D): 177.5 x 56.0 x 55.0 cm
Barcode	4242003865989 WHILE STOCKS LAST KI86SAF30 4242003583944



Model	K181RAFE0 (WHILE STOCKS LAST)	G181NAEF0 (WHILE STOCKS LAST)
Product description	iQ500 319 litre built-in full fridge	iQ500 211 litre built-in full freezer
Product features	100% CFC/HFC free Auto Defrost Dynamic Cooling freshSense 7 Segment electronic control Acoustic open door warning system superCool function Door right hinged, reversible	4 Freezer 100% CFC/HFC free noFrost 7 Segment electronic control Acoustic warning system, by temperature increase superFreeze function manual/automatic activation Freezing capacity: 20kg/24hrs Storage time in event of power failure: 22 hrs Door left hinged, reversible
Interior features	7 Safety glass shelves of which 6 height adjustable Bottle grid 6 Door bins, there of 1 dairy compartment Freshness System: 1 x hyperFresh plus box with adjustable humidity 1 x Fresh box	5 transparent freezer drawers varioZone - removable safety glass shelves for extra space
Product specs	Rating: 90W Fridge Capacity: 319 litres net Energy Consumption: 115 kWh/yr Unit dimensions (H x W x D): 177.2 x 55.8 x 54.5cm Aperture (H x W x D): 177.5 x 56.0 x 55.0cm	Rating: 120 W Fridge Capacity: 212 litres net Energy Consumption: 294 kWh/yr Unit dimensions (H x W x D): 177.2 x 55.8 x 54.5cm Aperture (H x W x D): 177.5 x 56.0 x 55.0cm
Barcode	424200384492	4242003863022

Model	KU15RADF0
Product description	iQ500 137 litre fully integrated bar fridge
Product features	100% CFC/HFC free Automatic defrost Door right hinged, reversible Ventilation in the plinth, no ventilation cut-out in the work surface necessary Variable plinth adaption Height adjustable feet Soft close door
Interior features	3 safety glass shelves of which 3 are height adjustable 1 Vegetable compartment Variable inner door with dairy compartment Bottle holder Interior with metal applications LED interior light
Product specs	Rating: 90W Capacity: 141 litres net Energy consumption: 92 kWh/yr Overall (H x W x D): 82.0 x 59.8 x 54.8cm Aperture (H x W x D): 82.0 x 60.0 x 55.0cm
Barcode	4242003848821

Dishwashers. Innovative features for sparkling results.

Siemens dishwashers feature modern design and innovative ideas for seamless living.

Experience maximum flexibility with practical innovations such as varioSpeed Plus which washes your dishes on selected programmes up to 66% faster and Zeolith® drying technology that transforms humidity into heat for gentle and effective drying results.

Our dishwashers include height-adjustable baskets and foldable racks, stylish innovations such as door openAssist and timeLight floor projection, all working together to provide you with the perfect balance between modern design and innovative technology. Whether you are serving dinner for family or hosting a party for friends, Siemens dishwashers ensure that you'll have sparkling clean dishes and glasses quickly.

Siemens dishwasher warranties:

For the machines featured in this brochure, we are also able to offer longer warranties on certain parts. This includes a 10 year Anti-Rust warranty on all dishwashers, a 10 year Compressor Drive warranty on selected cooling appliances, a 10 year iQDrive® warranty on selected washing machines and AquaStop lifetime warranty on selected washing machines and dishwashers.



Your daily forecast,
dry conditions,
brilliant views.



Welcome to a new era of dishwashing with brilliantShine.



Our brilliantShine system combines our low temperature glass care programme with our advanced water softening technology and Zeolith® drying to ensure your glassware is taken care of. Straight from dishwasher to table, Shine&Dry gives you streak-free, shining glasses. Harnessing the power of Zeolith® at its best, the special drying cycle also works just as well on plastics, pots and pans. Saving you time, you no longer need to give glasses an extra towel dry to smarten them up, allowing you to spend more time preparing for your guests arrival. With the brilliantShine system your glassware is always ready to shine for your guests, even unexpected ones.

That's what the new brilliantShine system with Zeolith® Drying is made for: creating the perfect conditions to start every day with a highlight, and sparkling glasses that you can be proud of.

The new brilliantShine system offers three intelligent solutions that take care of these factors:

- Zeolith® Drying uses a Zeolite mineral that absorbs moisture and converts it into a gentle heat.
- The Shine&Dry option swills all residues of detergent with extra rinsing water, resulting in streak free, shining glassware.
- The Glass 40°C programme ensures that your glassware is not exposed to excessive temperatures or spray pressures, and keeps the cycle time shorter.

Zeolith® Drying: Super efficient drying technology.



Using advanced drying technologies Siemens dishwashers keep energy consumption to a minimum. Zeolith®, a form of zeolite mineral has the astonishing ability to absorb moisture and convert it to heat. What does this mean for you? The heat produced naturally by the Zeolith® is used for the drying cycle. No additional energy is therefore required to heat up the contents of your dishwasher for the drying process (as with a standard drying system). This results in perfect drying, with less energy usage than models without Zeolith® technology.

Zeolith® is stored in the depths of the dishwasher; this regenerates itself and keeps working for the lifetime of the machine meaning you never have to replace it! Combine this with the economy 50°C programme to get brilliant results with minimal energy.

Drying phase
Zeolith® absorbs moisture and converts it to heat energy.

Cleaning phase
As the mineral is heated during the cleaning cycle, it is recharged and ready to absorb moisture once more



Key features in dishcare.



Model shown: SN678D06TG fully integrated dishwasher with blue emotionLight

Storage solutions for added flexibility and better results.



varioDrawer
By adding a third shelf for cutlery, varioDrawer removes the need for a cutlery basket and creates more space. Also available in varioDrawer Pro for added flexibility.



varioDrawer Pro
The varioDrawer Pro adds a third shelf for cutlery and removes the need for a cutlery basket, creating more space. Knives, forks and spoons are placed on their side, leaving them easier to remove when emptying the dishwasher.

With the varioDrawer Pro flexible sides can fold down to take items such as espresso cups, and areas in the tray can be adjusted to allow for larger handle cutlery.

Convenient blue touchpoints also indicate all the adjustment options available, such as lowering the side sections to accommodate bulkier items like espresso cups and ladles.



varioFlex basket system
The ability to fold down certain compartments within the cavity for extra room and flexibility. The top rack has 2 areas that can be adjusted for extra flexibility whilst the bottom basket has 4 areas that can be adjusted to create more space.



varioFlex Pro basket system
The varioFlex Pro basket system is designed to hold larger plates and allows you to create extra space for pots and pans with ease. Choose from up to 6 flexible areas in the top rack and up to 8 flexible areas in the bottom basket to create extra space. Blue touchpoints inside the baskets indicate all the adjustment options available at a glance. It's never been as easy to adjust the slats to suit each load, making the inside of your dishwasher constantly adaptable.



varioDrawer



varioDrawer Pro



varioFlex basket



varioFlex Pro basket



Floor projection displays.



infoLight
Projects a beam of light onto the floor to show the dishwasher is running. This prevents needing to open the door while the cycle is still on to see if it's finished.



timeLight
Check the status of the cycle easily. Useable on any surface of any colour, the innovative timeLight projects the remaining time as well as other essential information of the dishwasher cycle onto the floor. With quiet dishwashers, this solution lets you know the dishwasher is running and how long is left at a glance, so you can avoid opening the door mid-cycle.



infoLight

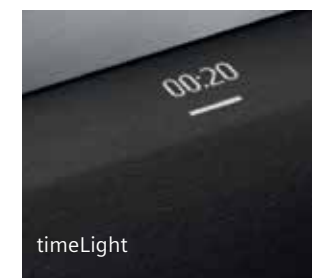

timeLight

Light up your dishwasher.



emotionLight
Siemens dishwashers feature an internal blue emotionLight that has the wow-factor. Creating a relaxed ambiance, the emotionLight uses LED lights to reflect off your brilliantly-cleaned glasses and create a cool blue glow emanating from inside your dishwasher when you open the door, and switching off again when you close it.



Added kitchen convenience.



Energy efficiency
All Siemens built-in dishwashers are rated between an A+ or A+++ for efficiency.



Silence programme
You'll barely hear our dishwashers running. When the Silence programme is selected the dishwashers noise level is reduced by 2 – 3dB so you can relax in peace. This is achieved by decreasing water pressure and extending run time. Values stated in matrix under noise level.



hygienePlus
Great for cleaning chopping boards, food containers and utensils, the hygiene option kills bacteria and germs. Providing a simple solution to the upkeep of your family's health, the final rinse heats up to 70°C regardless of the cycle you choose.*
*Not on delicate programme.

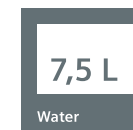

Water consumption
Our built-in dishwashers' lowest water usage programme is 6.5L per cycle* if the Eco 50 programme is selected, for the most resource efficient option.

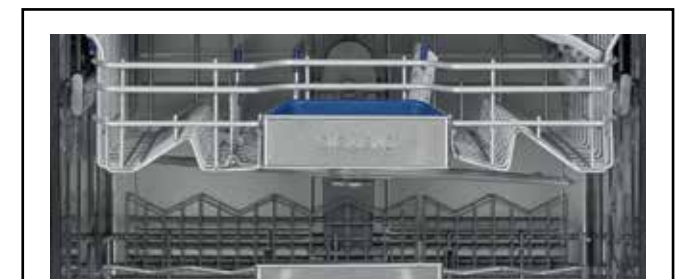

Machine Care with Siemens dishwashers
For excellent results when washing and drying, it is important to look after your dishwasher correctly. All of our integrated Siemens dishwashers include the Machine Care Programme. This is designed to be used together with a dishwasher cleaning detergent and provides a short, high temperature, high pressure wash designed to remove limescale and grease build up inside your dishwasher and outlet pipes. With iQ700 and iQ500 the dishwasher will remind you every 30 cycles or so to run this programme, to keep your appliance running as efficiently as possible.

Take your mind off the household chores using the Home Connect App.

Connect your Wi-Fi-ready dishwasher with the Home Connect App to easily select programmes and options to start your dishwasher from wherever you are, whenever you want. Thanks to this app technology, you can control your appliance out of home and have the dishes ready exactly when you need them. Perfect for busy lifestyles. When the cycle is finished, the Home Connect App will send you a push notification to let you know, so you can focus on other things.

You can also select a number of great features through the Home Connect app, such as Speed on demand, Silence on demand, autoOpen Dry and you can set your Favourite programme and option combination, giving you flexibility to alter your wash cycle options from wherever you are to sync perfectly with your day.

easyStart menu

The easyStart menu on the Home Connect App helps you to find the correct setting for your load quickly and easily. Just answer a few simple questions and the app will suggest the most optimum programme for your load. It is easy to adjust your dishwasher settings via the app on your mobile or tablet to keep it running at maximum efficiency.

Home Connect partner Services

You can even use our partner services, Amazon Alexa and IFTTT to manage your machine. With Amazon Alexa, you can control your appliance by using your voice. Whether you want to start or finish the cycle, or check the remaining cycle time, just ask Alexa. Also works with Google assistant.

You can also benefit from automatic tablet replenishment, through Smart reorder within the Amazon Alexa app. This feature can be set up easily, so you never need to worry about running out of

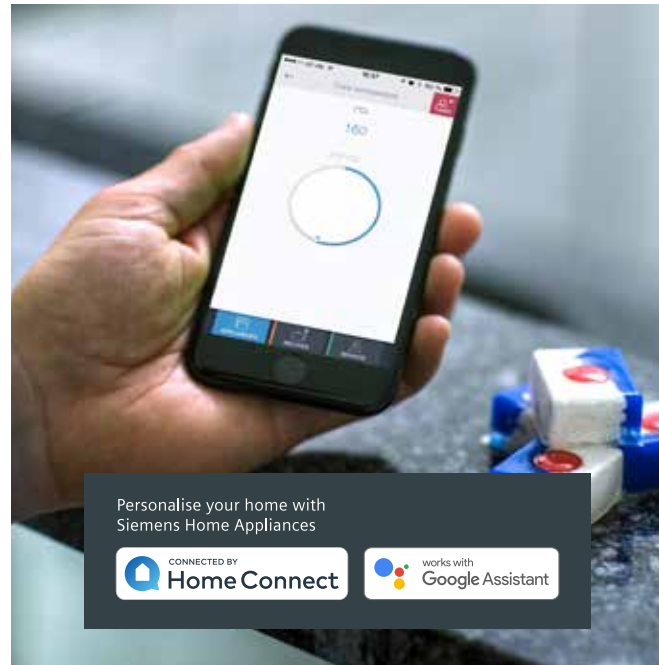

tablets again. Setting your water settings has never been easier too. Whether your area experiences hard or soft water, you can set this easily within the app in seconds.

IFTTT technology allows you to integrate the Home Connect App with a wider array of connect devices. You can then produce customised applets, demands between two devices, so you can really bring your smart home to life. For example you could make your lights flash when your cycle finishes.



Features available on all dishwasher models.



varioSpeed Plus

Use the varioSpeed Plus button to run the dishwasher significantly faster without compromising on wash quality. Standard on all models.

Speed on demand

An advanced functionality of varioSpeed Plus that cleans and dries the dishes in the shortest possible time for individual needs. This option can be selected, even if a programme is already running, activate this feature via the Home Connect App.



dosageAssist

Quickly and evenly dissolves dishwasher tablets throughout the entire machine, leaving no mess to clean at the end of the cycle. This also prevents the tablet getting stuck in your dishware ensuring no cleaning product residue is left after the cycle.



extraDry

The "extraDry" option can be added to any programme and will extend the drying cycle. This can be useful for harder to dry loads.



intensiveZone

Delicate items and pots and pans can be cleaned together in the same wash. The intensiveZone option increases the spray pressure and temperature in the bottom basket to handle burnt on pans, whilst delicate items can be washed safely in the top basket.

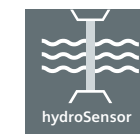

hydroSensor

Makes sure that the optimum temperature is used depending on how dirty the dishes are, meaning that dishes are perfectly clean the first time round.



Heat exchanger

Protect your glasses from cracking with gentle water heating. Heat generated during the wash cycle is used to pre-heat the rinsing water to stop glasses being put under stress. Standard on all models.

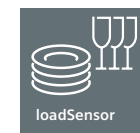

loadSensor

By monitoring that the optimum amount of water is flowing through the dishwasher throughout the cycle, loadSensor helps to ensure that dishes are cleaned thoroughly.



Favourite

Your personal favourites in one push: The Favourite button makes your dishwasher even more personal. Simply enter your most used combination of dishwashing programmes and options, and then start them conveniently at the touch of a button, via the Home Connect app or via your voice assistant.

A modern handleless kitchen.

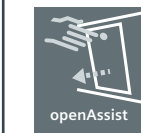

openAssist

With door openAssist you can open fully integrated dishwashers by simply touching the front of the unit, making loading and unloading easy. This removes the need for a handle and is the ideal choice for designer kitchens. With this feature you can even implement a child lock so that the appliance requires two gentle touches before opening.



Discover top of the range
TFT Displays and seamlessly
fitted varioHinge options.

Choose the display type that is right for you.

Black touch control with TFT display and real-time clock

The clear, touch control high resolution TFT display makes it easy to select programmes and settings and check the status of your dishwasher at a glance. Thanks to the real-time clock, it's now possible to set the exact time that you want your dishes to be ready by, for extra convenience. Perfect for delivering warm plates to the dinner table.



Black touch control with LED display

Retaining the same top of the range sleek black touch control panel, however with a clear LED display screen which displays the programme setting and duration time.



Stainless steel push button control panel with LED display

This sleek design includes stainless steel buttons and a clear LED screen which displays the programme setting and duration time.



Black push button control panel with LED display

With black buttons and an LED screen which displays programme settings and duration time, this easy to use interface is practical and stylish.



varioHinge. The ideal solution for extra long cabinet doors.

varioHinge enables the furniture panel to slide up the appliance door as it opens, avoiding collision with the plinth.

Siemens has two built-in dishwasher models, SN758D21TE and SX736X03ME with varioHinge. varioHinge ensures your kitchen design can be completely flexible with the installation of your dishwasher. Perfect for cabinet doors in handleless kitchens, or designs with low baseboards and longer cabinet panels, the varioHinge allows the cabinet door to be pushed upwards when opened to avoid the door catching. The varioHinge reduces the bottom gap between cabinet doors too for a seamless finish to your kitchen. These appliances are suitable for use with a 50mm plinth.



- ✓ Attractive design for high installation thanks to minimal gap size made possible by varioHinge.
- ✓ With the variable hinge varioHinge, a lower plinth height is possible.



Dishwashers with varioHinge – high installation



Model	SN63HS01MZ	SN73HX01CZ
Product description	iQ300 60cm fully integrated dishwasher, Home Connect 4 temperatures	iQ300 60cm fully integrated dishwasher, Home Connect 4 temperatures
Programmes	Intensive 70°C, Auto 45-65°C, Eco 50°C, Quick 45°C, 1h 65°C Special Program: myFavourite Special functions: Remote Start, Intensive Zone, Extra Rinse, varioSpeed Plus, Machine Care Silence on demand (via app)	Intensive 70°C, Auto 45-65°C, Eco 50°C, Quick 45°C, 1h 65°C Special Program: myFavourite Special functions: Remote Start, Intensive Zone, halfLoad, varioSpeed Plus, Machine Care Silence on demand (via app)
Comfort and safety	Number of standard place settings: 13 dosageAssist iQdrive aquaSensor, Load-Sensor Detergent Automation Heat Exchanger – for hygienic drying, prevents thermal shock hydroDry - hygienic and efficient drying Glass care protection system Electronic delay timer (1-24 hours) and time remaining display Push buttons top control Acoustic end of cycle indicator infoLight LED salt and rinse aid refill indicator varioFlex basket system varioDrawer Height adjustable top basket with 3 stage rackMatic Rack Stopper to prevent derailing of bottom basket automatic filter cleaning system with 3-fold corrugated filter Dishwasher cavity: Stainless Steel aquaStop with guarantee against flooding	Number of standard place settings: 14 dosageAssist iQdrive aquaSensor, Load-Sensor Detergent Automation Heat Exchanger – for hygienic drying, prevents thermal shock hydroDry - hygienic and efficient drying Glass care protection system Electronic delay timer (1-24 hours) and time remaining display Push buttons top control Acoustic end of cycle indicator infoLight LED salt and rinse aid refill indicator Flex basket system varioDrawer Height adjustable top basket with 3 stage rackMatic Rack Stopper to prevent derailing of bottom basket varioHinge automatic filter cleaning system with 3-fold corrugated filter Dishwasher cavity: Stainless Steel aquaStop with guarantee against flooding
Product specs	Dimensions (H x W x D): 81.5 x 59.8 x 55.0cm Aperture (H x W x D): 81.5 – 87.5 x 60.0 x 55.0 cm Consumption rate: Eco50°C/9.5l/0.92kWh/295min Rating: 2400 W Noise level: 46dB	Dimensions (H x W x D): 81.5 x 59.8 x 55.0cm Aperture (H x W x D): 81.5 – 87.5 x 60.0 x 55.0 cm Consumption rate: Eco50°C/9.5l/0.93kWh/295min Rating: 2400 W Noise level: 44dB
Barcode	4242003895689	4242003895825

Installation diagrams

OVENS

COMPACT APPLIANCES

CT636LES1

Bean and water containers are removed from the front. Recommended installation height 95-145 cm.

MICROWAVE OVENS

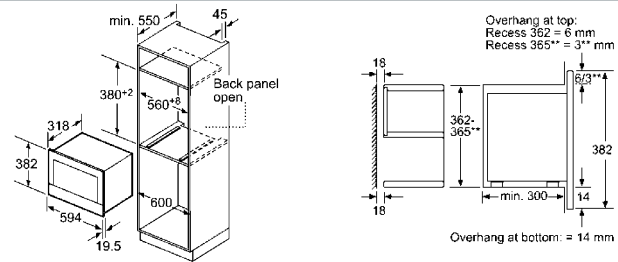

BE634RGS1 / BE634LGS1

WARMER DRAWERS

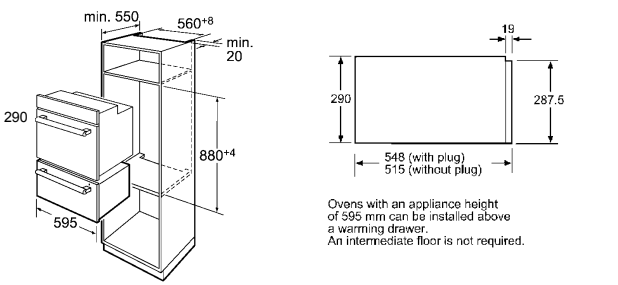

BI630DNS1

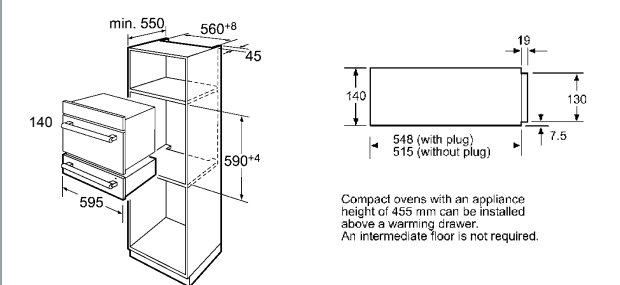

BI630CNS1

INDUCTION HOBS

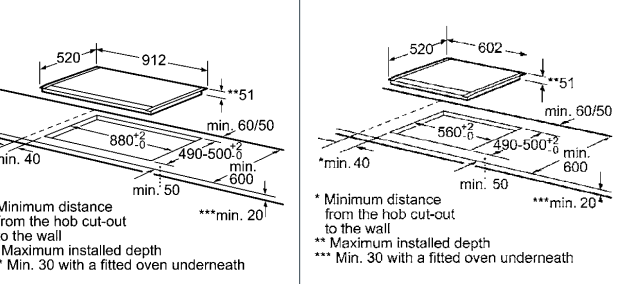

EX975LVC1E

EX675LEC1E*

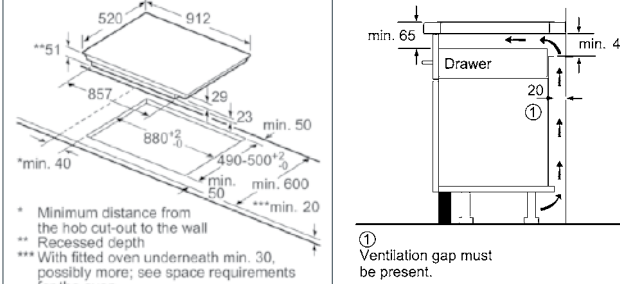

EX975KXWIE

*For all induction hobs

HOBS

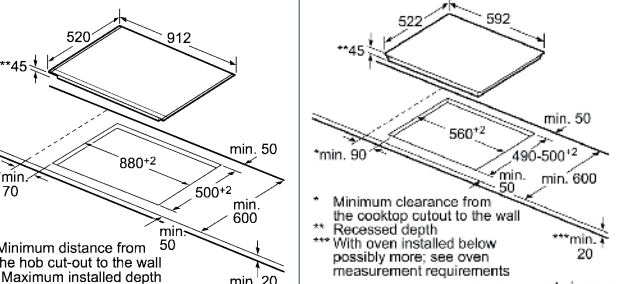

ET975LMP1D

ET611HE17E

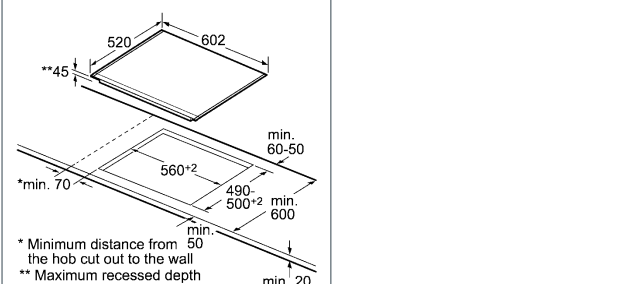

ET675FNP1E / ET67517E

DOMINO HOBS

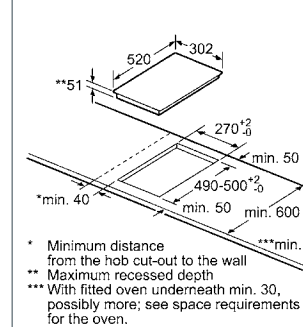

EX375FXB1E*

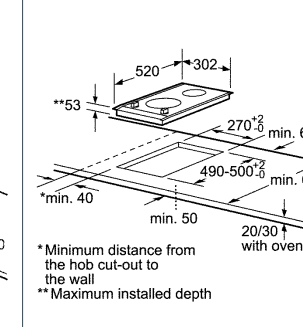

EH375FBB1E

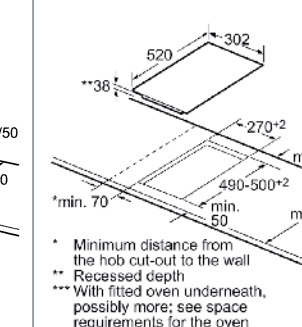

ET375FFP1E

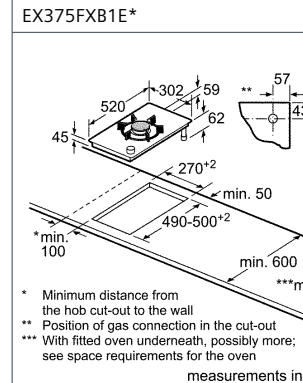

ER3A6AD70

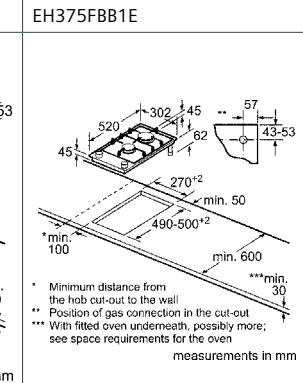

ER3A6BD70

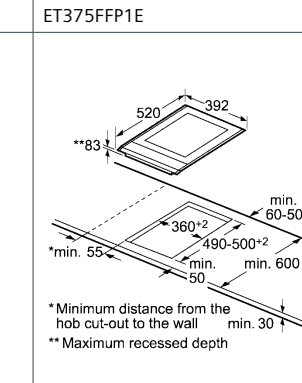

ET475FYB1E

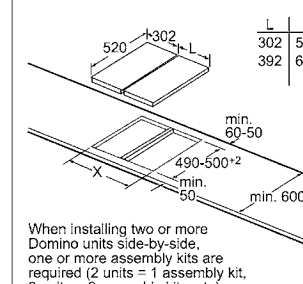

Applies to 30cm domino hobs

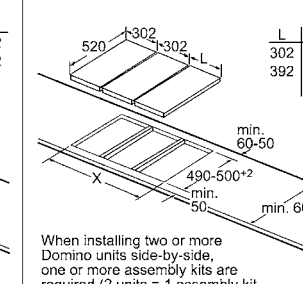

Applies to 30cm domino hobs

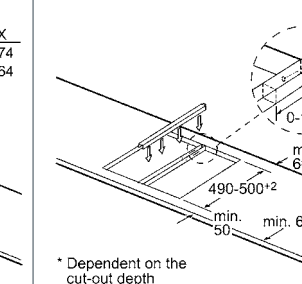

Assembly kit HZ394301 for all domino hobs

GAS HOBS / STEPFLAME

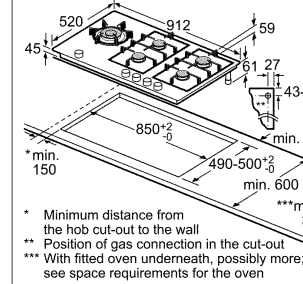

ER9A6SD70

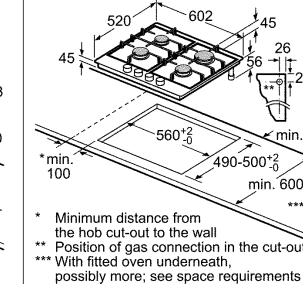

ER6A6PD70

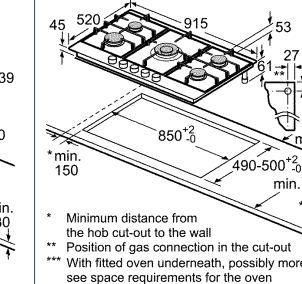

EC9A5RB90

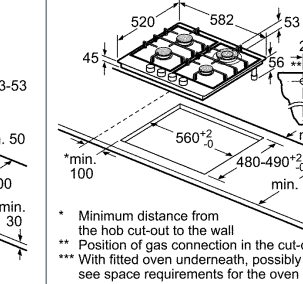

EC6A5HC90

EXTRACTORS

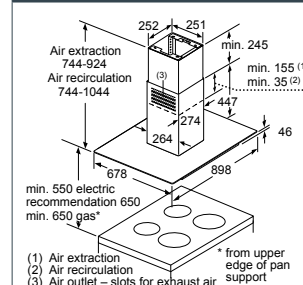

LF978BM50

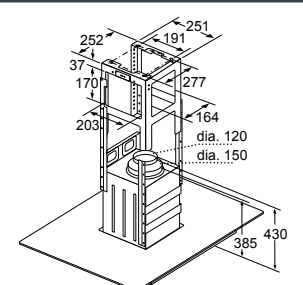

LC668HM50

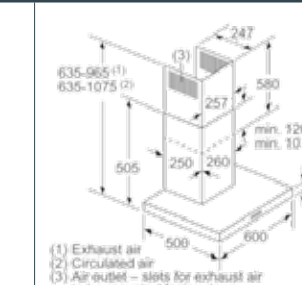

LC668HM50

EXTRACTORS

Combination with electric hob

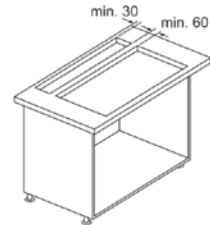

For use with gas hob see drawing "Combination with gas hob".
measurements in mm

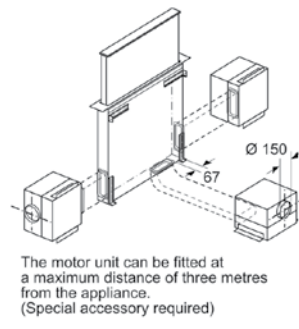

The motor unit can be fitted at a maximum distance of three metres from the appliance. (Special accessory required)

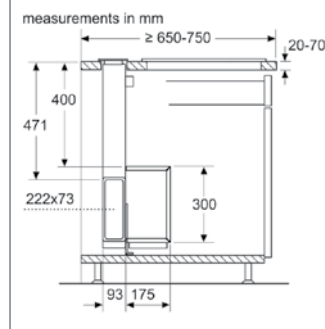
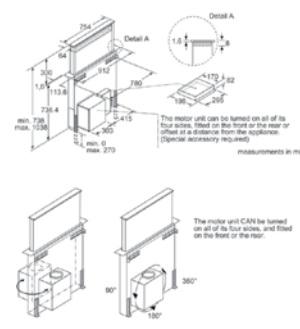

measurements in mm

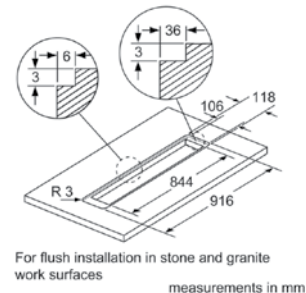

For flush installation in stone and granite work surfaces
measurements in mm

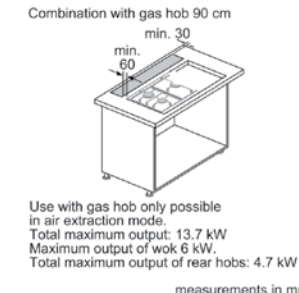

Use with gas hob only possible in air extraction mode.
Total maximum output: 13.7 kW
Maximum output of wok 6 kW
Total maximum output of rear hobs: 4.7 kW
measurements in mm

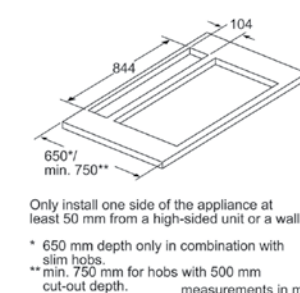

Only install one side of the appliance at least 50 mm from a high-sided unit or a wall.
* 650 mm depth only in combination with slim hobs.
** min. 750 mm for hobs with 500 mm cut-out depth.
measurements in mm

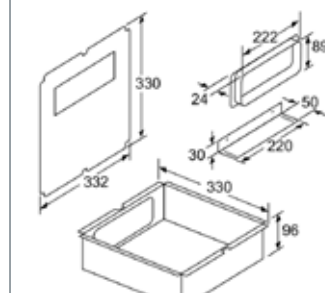

measurements in mm

LD97DBM60B

LZ291DM00

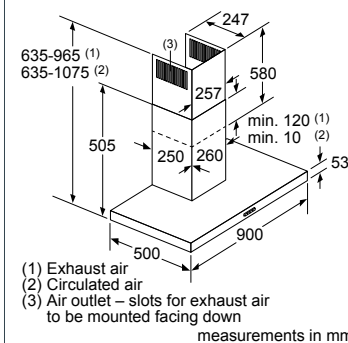

(1) Exhaust air
(2) Circulated air
(3) Air outlet – slots for exhaust air to be mounted facing down
measurements in mm

LC94BBC50

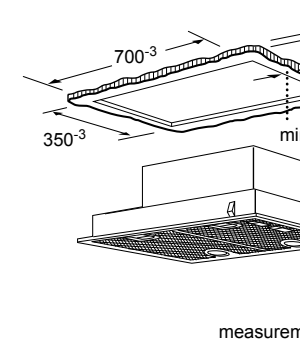

measurements in mm

LB75565

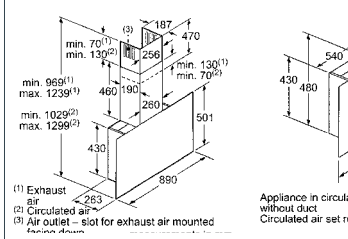

(1) Exhaust air
(2) Circulated air
(3) Air outlet – slot for exhaust air mounted facing down
measurements in mm

LC97FQP60

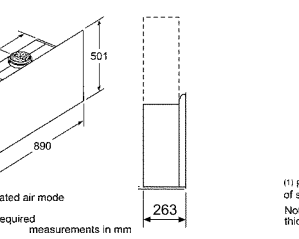

Appliance in circulated air mode without duct
Circulated air set required
measurements in mm

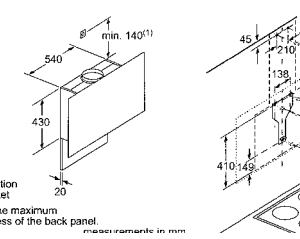

(1) Position of socket
Note the maximum thickness of the back panel.
measurements in mm

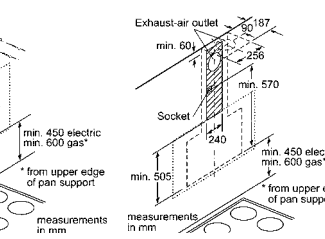

Exhaust-air outlet
min. 60
min. 570
min. 450 electric
min. 500 gas*
min. 450 electric
min. 500 gas*
* from upper edge of pan support
* from upper edge of pan support
measurements in mm

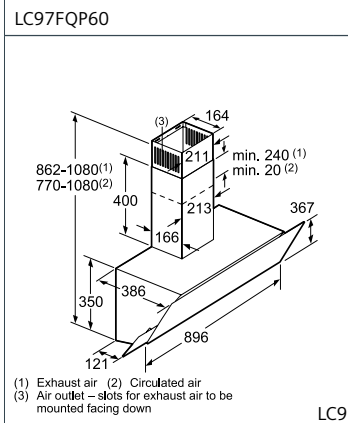

(1) Exhaust air (2) Circulated air
(3) Air outlet – slots for exhaust air to be mounted facing down
measurements in mm

LC95KA670

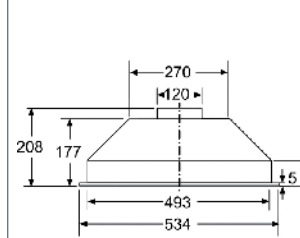

measurements in mm

LB53NAA50

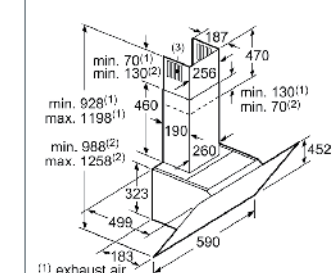

(1) exhaust air
(2) circulating air
(3) air outlet – install exhaust air slits facing down
measurements in mm

LC67KHM60

EXTRACTORS

The fan outlet can be turned in all four directions

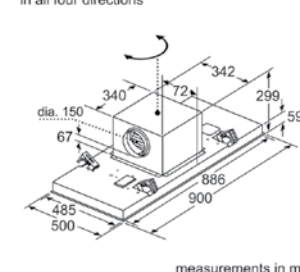

measurements in mm

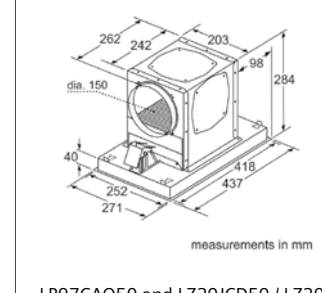

LR97CAQ50 and LZ20JCD50 / LZ20JCC50

measurements in mm
Air extraction

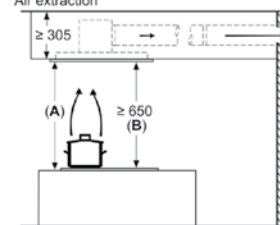

A: Optimum performance 700-1500
B: From upper edge of pan support

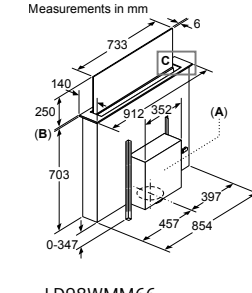

measurements in mm
Air recirculation

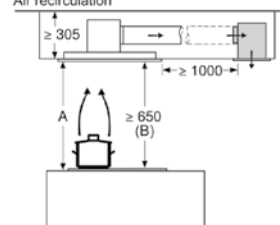

A: Optimum performance 700-1500
B: From upper edge of pan support

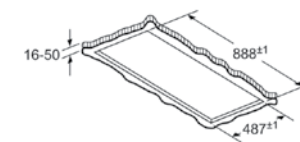

Never fit directly onto plasterboard or similar lightweight construction materials of the suspended ceiling. A suitable substructure is required that is securely fixed to the concrete ceiling.

measurements in mm

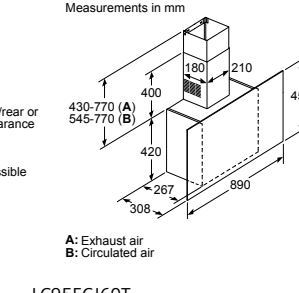

A: Exhaust air
B: Circulated air

LC95FCJ60T

COOLING

Maximum allowable weight of furniture fronts

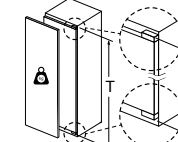

Installed furniture doors that exceed the allowable weight can cause damage and impaired functionality of the hinge.

Hinges in mm:	non-dampened hinge, Door in kg:	dampened hinge, Door in kg:
1500-1750	22	22

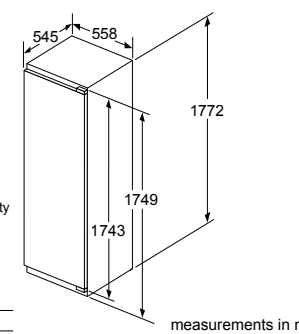

measurements in mm

KI81RAF30/GI81NAE30 (Fridge Left Hinged/Freezer Right Hinged)

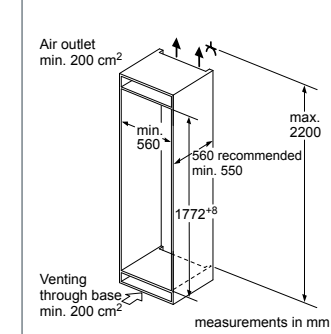

measurements in mm

KI81RAFE0

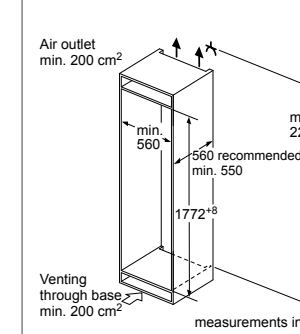

measurements in mm

GI81NAEFO

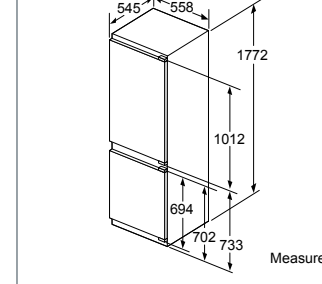

KI86SAFE0

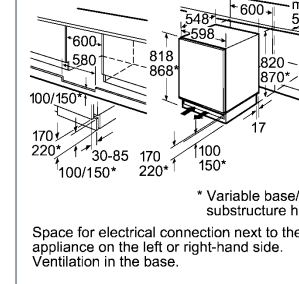

KU15RADFO

DISHWASHERS

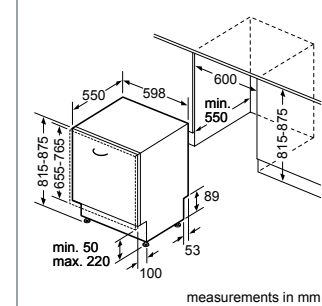

SN73HX01CZ

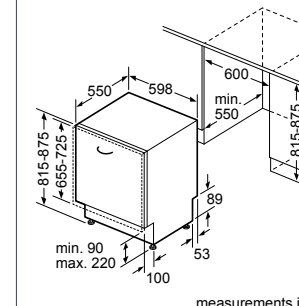

SN63HS01MZ

Customer Service



Built-in Appliances

Total guarantee period: 5 years from date of purchase.
Terms and conditions apply.



BSH Service Centre

Tel: 0860 026 724

Fax: 0861 171 780

E-mail: bsh@iopen.co.za

Guarantee Conditions

Guarantee is not valid if appliances are used in an industrial application. Appliance must be installed by a licensed tradesman according to BSH and national or local regulations.

Total guarantee period for built-in appliances: 5 years from date of purchase.

Total guarantee period for CT636LES1 coffee machine: 3 years from date of purchase.

Transport damages will only be accepted 7 days after delivery to end user or contractor working on behalf of end user (kitchen company, building contractor).

First year full guarantee on parts and labour – excluding very fragile parts i.e. glass, plastic, light bulbs.

Second and third year on functional parts only: electronics, timers, switches, locks, clocks, thermostats, fans plus labour to repair or replace.

Fourth and fifth year on functional parts only: electronics, timers, switches, locks, clocks, thermostats, fans plus labour to repair or replace.

After guarantee expires, customer must pay a charge of R430 excl. VAT (annual increase applies) towards labour costs.

Condition governing appliance service

1. A guarantee claim ceases once repair or work is undertaken by a person not entitled by BSH to do so or if the appliance is provided with spare parts, attachments or accessories that are not original, therefore causing damage.
2. The guarantee is given in such a manner that defective parts are repaired free of charge or – and this is BSH choice – replaced by perfect parts.
3. A claim under guarantee does not cause an extension of the guarantee period nor does it start a new guarantee period.
4. If BSH refuses repair or repair fails and the end user so requires, a replacement of equal value is supplied free of charge within the above guarantee period.
5. These conditions of guarantee are applicable to appliances purchased in South Africa. If appliances are taken abroad and meet the technical requirements (e.g. voltage, frequency, type of gas etc) of such country while also being suitable for the respective climate and environmental conditions, these terms of guarantee are applicable only if BSH have an approved customer service network in such country.

* Valid from February 2008

Siemens Home Appliances

Head Office

37 Commerce Crescent (First Floor)

Kramerville

Johannesburg

Tel: (011) 265-7800

Fax: (011) 265-7817

Brand Experience Centre Johannesburg

30 Archimedes Street

Kramerville

Johannesburg

2148

Tel: 064 452 7178

Brand Experience Centre Cape Town

17 Church Street

Bree Street Studios

Cape Town

8000

Tel: 081 432 1087

siemens-home.bsh-group.com/za/

BSH Group is a Trademark Licensee of Siemens AG.

Please note that certain features apply to particular products. Siemens built-in appliances are guaranteed for 5 years and CT636LE51 coffee machine for 3 years from date of purchase against faulty workmanship and/or material. No responsibility is accepted for printing errors. E&OE.